

Transport and Telecommunication, 2009, Volume 10, No 2, 16–25
 Transport and Telecommunication Institute, Lomonosova 1, Riga, LV-1019, Latvia

RELIABILITY OF FATIGUE-PRONE AIRFRAME. INSPECTION PROGRAM CONTROL

Yury Paramonov, Andrey Kuznetsov

*Aviation Institute, Riga Technical University
 Lomonosova Str. 1, Riga, LV-1019, Latvia
 Ph.: +371 67255394. Fax: +371 67089990*

E-mail: yuri.paramonov@gmail.com, andreyk@hotmail.ru

Algorithm of inspection program development and control using theory of Markov chains and p-set function definition on the base of processing of approval lifetime test result is discussed. We make assumption that some Structural Significant Item (SSI), the failure of which is the failure of the whole system, is characterized by a random vector (r.v.) (T_d, T_c) , where T_c is critical lifetime (up to failure), T_d is service time, when some damage (fatigue crack) can be detected. We suppose also that a required operational life of the system is limited by the so-called Specified Life (SL), t_{SL} , when system is discarded from service. Some examples are given.

Keywords: inspection program, Markov chains, reliability

1. Introduction. Failure Probability Calculation Using Theory of Markov Chains

This paper is development of previous author papers [1,2,3]. Airframe inspection program control planning can be constructed using theory of Markov Chains. For this purpose the inspection program is presented as a process of several states: first $n + 1$ states, E_1, E_2, \dots, E_{n+1} , represent aircraft service in the appropriate interval between two consequent inspections, service time $t \in [t_{i-1}, t_i)$, $i = 1, 2, \dots, n + 1$, $t_0 = 0$, $t_{n+1} = t_{SL}$, (an aircraft is discarded from service at specified life, t_{SL} , even if there are no cracks discovered by the time moment t_{SL}), while three additional states, $E_{n+2}, E_{n+3}, E_{n+4}$, represent aircraft withdrawal from the service due to (1) the successful end of service when the specified life period is over ($E_{n+2} = \text{SL-state}$), (2) due to fatigue failure ($E_{n+3} = \text{FF-state}$) and (3) due to discovery of a crack ($E_{n+4} = \text{CD-state}$). Let the probability of crack detection during the inspection number i at time moment t_i is denoted as v_i ; probability of failure in service time interval (t_{i-1}, t_i) as q_i ; and probability of absence of above-mentioned events as u_i . Since these three cases form a complete set $u_i + v_i + q_i = 1$. In our model we also assume that there is an inspection at t_{SL} also. This inspection at the end of $(n+1)$ -th interval does not change the reliability but it should be done in order to know the state of aircraft (there is fatigue crack or there is not fatigue crack). The transition probability matrix of this process can be composed as it is presented on Fig 1.

	E_1	E_2	E_3	\dots	E_n	E_{n+1}	E_{n+2} (SL)	E_{n+3} (FF)	E_{n+4} (CD)
E_1	0	u_1	0	\dots	0	0	0	q_1	v_1
E_2	0	0	u_2	\dots	0	0	0	q_2	v_2
\dots	\dots	\dots	\dots	\dots	\dots	\dots	\dots	\dots	\dots
E_{n-1}	0	0	0	\dots	u_{n-1}	0	0	q_{n-1}	v_{n-1}
E_n	0	0	0	\dots	0	u_n	0	q_n	v_n
E_{n+1}	0	0	0	\dots	0	0	u_{n+1}	q_{n+1}	v_{n+1}
E_{n+2} (SL)	0	0	0	\dots	0	0	1	0	0
E_{n+3} (FF)	0	0	0	\dots	0	0	0	1	0
E_{n+4} (CD)	0	0	0	\dots	0	0	0	0	1

Figure 1. The transition probability matrix

In this paper we suppose the exponential approximation of fatigue crack growth function when fatigue crack size, $a(t)$, is described by equation $a(t) = a_0 \exp(Qt)$, where $a_0 = a(0)$ is equivalent initial crack size[4,5]. Despite of all simplicity, this formula shows us rather comprehensible results in interval (T_d, T_c) , where T_c is critical lifetime (up to failure), T_d , is service time, when some damage (fatigue crack) can be detected with probability equal to unit:

$$T_d = (\ln a_d - \ln a_0) / Q = C_d / Q, T_c = (\ln a_c - \ln a_0) / Q = C_c / Q,$$

where a_d is a crack size, when the probability to discover it is equal to unit, a_c is a crack size, which corresponds to the maximum residual strength of an aircraft component allowed by special design regulation.

We see that parameters C_c and C_d can be derived each from another:

$$C_d = C_c - \delta, \text{ where } \delta = \ln a_c - \ln a_d = \ln \frac{a_c}{a_d},$$

If δ is some constant then actually for considered model of fatigue crack growth the distribution of r.v. (T_d, T_c) is defined only by two random variables (parameters of fatigue crack growth): C_c and Q . Let us denote $X = \ln Q$ and $Y = \ln C_c = \ln(\ln(a_c / \alpha))$. From the analysis of the fatigue test data it can be assumed, that the logarithm of time required the crack to grow to its critical size (logarithm of durability) is distributed normally. It comes from the additive property of the normal distribution that $\ln T_c$ could be normally distributed either if both $\ln C_c$ and $\ln Q$ are normally distributed. So we suppose that random variables $X = \log(Q)$ and $Y = \log(C_c)$ have normal distributions with unknown mean values θ_{0X} , θ_{0Y} and known standard deviations and correlation coefficient $\theta_{1X}, \theta_{1Y}, r$. We suppose that if in interval (T_d, T_c) some inspection will be made then fatigue failure will be eliminated.

These assumptions allow calculating of

$$\begin{aligned} u_i &= P(T_d > t_i | T_d > t_{i-1}) = P(Q < C_d / t_i) / P(Q < C_d / t_{i-1}); \\ q_i &= P(t_{i-1} < T_d < T_c < t_i | t_{i-1} < T_d) = \\ &\begin{cases} 0, & \text{if } t_{i-1} C_c / C_d > t_i, \\ P(C_c / t_i < Q < C_d / t_{i-1}) / P(Q < C_d / t_{i-1}), & \text{if } t_{i-1} C_c / C_d \leq t_i, \end{cases} \\ v_i &= 1 - u_i - q_i; \end{aligned} \tag{1}$$

Unfortunately, corresponding integrals are not expressed by elementary functions, but if it is assumed that C_c and C_d are some constants then we have

$$u_i = a_i / a_{i-1}, q_i = \max(0, (a_{i-1} - b_i) / (1 - a_{i-1})),$$

where $a_i = \Phi(\ln(C_d / t_i) - \theta_0) / \theta_1$, $b_i = \Phi(\ln(C_c / t_i) - \theta_0) / \theta_1$, $\Phi(\cdot)$ is distribution function of standard normal variable. It is necessary to mention, that if we consider a park of N aircraft of the same type and if we are interested to know the probabilities of the failure of at least one aircraft or crack discovery in at least one aircraft of the park then instead of q_i, u_i and v_i we should use $q_{i,N} = 1 - (1 - q_i)^N$, $u_{i,N} = (u_i)^N$ and $v_{i,N} = 1 - q_{i,N} - u_{i,N}$. Let us denote the corresponding matrix by symbol P_N . The structure of considered matrices can be described in the following way (Figure 2):

Q	R
0	I

Figure 2. Sub-matrices of transition probabilities matrix

Here I is matrix of identity corresponding to absorbing states, 0 is matrix of zeros. Then matrix of probabilities of absorbing in different absorbing states for different initial transient states is defined by formula

$$B = (I - Q)^{-1} R. \tag{2}$$

First row of the matrix B defines the probabilities of absorption in states SL, FF, CD if initial state is E_1 . Particularly, $B(1,2)$ defines the failure probability for new aircraft which begin operation in first interval. For the park of N aircraft, $B_N(1,2)$ is a probability of at least one aircraft failure in this park. The following rows of the matrix B and B_N define the same probabilities for different initial states: for aircraft which begins operation in different time intervals. So if, for example, all N aircraft of the considered fleet begin operation in first interval simultaneously then the failure probability of at least one aircraft in the fleet is equal to

$$p_f = aB_N b, \tag{3}$$

where vector row $a = (1, 0, \dots, 0)$ means that all aircraft begin operation in first interval (state E_1), vector column $b = (0, 1, 0)'$.

2. Failure Probability Calculation Using Markov Chains Theory for Specific Inspection Program Control

Markov Chains theory is especially attractive to model various scenarios of switching to the alternative inspection programs when the certain event takes place. In this section we consider example of the following specific strategy. Let in the fleet at the beginning of service there was N aircraft. When the first crack is discovered in the fleet we make repair of corresponding aircraft (so that its failure in following operation will be eliminated) and double the frequency of inspections of the remaining $(N-1)$ aircraft. And suppose that in following we will not change the inspection program for any aircraft.

Here we consider the failure probability calculation in special case, when in initial inspection program we have only two inspections. For this simple example after fatigue crack discovery the remaining inspection intervals for the others aircraft are parted into two parts. The decision to double inspection number (or, which is the same, decrease two times the inspection interval) graphically looks as it is shown on Figure 3.

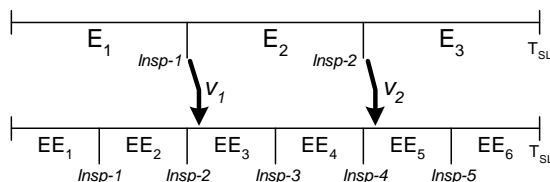

Figure 3. Switching to double inspection frequency for initial two-inspection program

As we can see, this decision is equivalent to continuation of service (of every specific aircraft) in accordance with inspection plan based on 5 inspections. The corresponding transformation of initial states graph is shown on Figure 4.

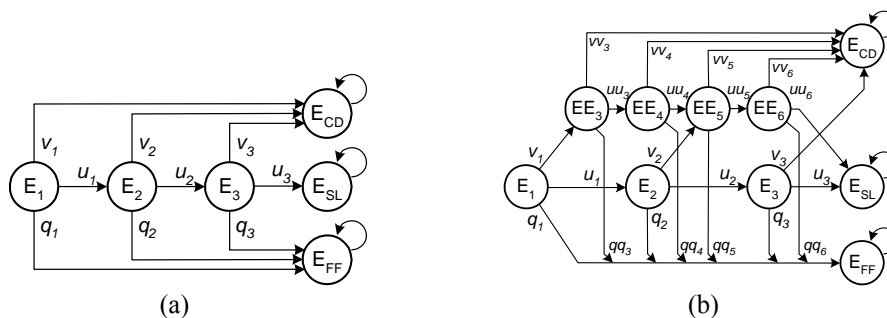

Figure 4. Ordinary two-inspection strategy state graph (a) for initial two-inspection program and switching to the double inspection frequency state graph (b).

For failure probability calculation it is convenient to introduce new “quasi-absorbing” states $CD1$ and $CD2$ (see Figure 5), corresponding to states EE_3 and EE_5 (see Figure 4.b) of the initial matrix. The states $CD1$ and $CD2$ are quasi-absorbing states corresponding to “absorption” of “initial process” at the inspection 1 and inspection 2. But really these are the points of beginning of “new” processes with different inspection programs.

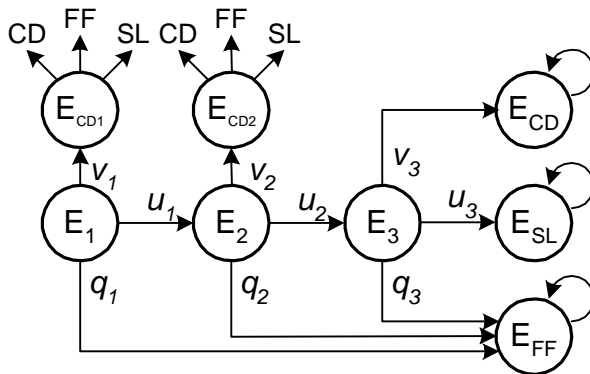

Figure 5. Switching to the double inspection frequency reduced state graph for initial two-inspection program

Corresponding transition probability matrix is shown on Figure 6.

	E_1	E_2	E_3	E_4 (SL)	E_5 (FF)	E_6 (CD)	E_7 (CD 1)	E_8 (CD 2)
E_1	0	$u_{1,N}$	0	0	$q_{1,N}$	0	$v_{1,N}$	0
E_2	0	0	$u_{2,N}$	0	$q_{2,N}$	0	0	$v_{2,N}$
E_3	0	0	0	$u_{3,N}$	$q_{3,N}$	$v_{3,N}$	0	0
E_4 (SL)	0	0	0	1	0	0	0	0
E_5 (FF)	0	0	0	0	1	0	0	0
E_6 (CD)	0	0	0	0	0	1	0	0
E_7 (CD1)	0	0	0	0	0	0	1	0
E_8 (CD2)	0	0	0	0	0	0	0	1

Figure 6. The matrix $P_N IP^0$ corresponding to the Figure5.

As in previous case the matrix of probabilities of absorption in different absorbing states for different initial transient states is defined by formula

$$B = (I - Q)^{-1} R.$$

It is obvious that now we have the random inspection program (IP), which has in fact three possible realizations:

$$\begin{aligned}
 IP^0 &: \{t_1, t_2, t_3\}, \\
 IP^1 &: \{t_1, (t_1 + t_2) / 2, t_2, (t_2 + t_{SL}) / 2, t_{SL}\}, \\
 IP^2 &: \{t_1, t_2, (t_2 + t_{SL}) / 2, t_{SL}\}.
 \end{aligned}$$

The probability of each scenario to realize depends on the probability to discover a crack during the inspections of the basic scenario. Probability of IP^1 is equal to probability of absorption in state CD1, $p(CD1)$. Probability of IP^2 is equal to probability of absorption in state CD2, $p(CD2)$. Probability of IP^0 , $p(IP^0)$, is equal to $1 - p(CD1) - p(CD2)$. For IP^0 the corresponding list of states in corresponding Markov chain is defined in Figure 4.a: $E_1, E_2, E_3, SL, FF, CD$. For IP^1 it is defined in Figure 4.b: $E_1, EE_3, EE_4, EE_5, EE_6, SL, FF, CD$. For IP^2 it is defined in Figure 4.b also: $E_1, E_2, EE_5, EE_6, SL, FF, CD$.

For every scenario, using already described approach we can calculate the probability of failure and then to calculate total probability of failure of at least one aircraft in a fleet:

$$\begin{aligned}
 p_f &= B_N IP^0(1, 2) + B_N IP^0(1, 4)(1 - (1 - B_1 IP^1(2, 2))^{N-1}) \\
 &+ B_N IP^0(1, 5)(1 - (1 - B_1 IP^2(3, 2))^{N-1})
 \end{aligned} \tag{4}$$

where $B_N IP^r(i, j)$ is (i, j) -th element of matrix B_N for IP^r inspection program, $r = 1, 2$, for fleet with N aircraft. Rows of matrix $B_N IP^1$ correspond to transient states: $E_1, EE_3, EE_4, EE_5, EE_6$. Columns correspond to absorbing states: SL, FF and CD . For matrix $B_N IP^2$ rows corresponding to transient states are: E_1, E_2, EE_5, EE_6 . Columns correspond to the same absorbing states: SL, FF and CD . Matrix P for inspection program IP^0 can be seen on Figure 1 if $n = 2$. Structure of the matrix $B_N IP^0$ is shown on Figure 7.

	E₄ (SL)	E₅ (FF)	E₆ (CD)	E₇ (CD 1)	E₈ (CD 2)
E₁					
E₂					
E₃					

Figure 7. Structure of the matrix $B_N IP^0$

3. Failure Probability Calculation for Inspection Program Control in General Case

In general case in the initial IP there are n inspections and in corresponding matrix of transition probabilities, see Figure 8, there are $(n + 1)$ transient and $(n + 3)$ absorbing states: three initial absorbing states (SL, FF and CD) and n additional quasi-absorbing states

	E ₁	E ₂	...	E _{n+1}	E _{SL}	E _{FF}	E _{CD}	E _{CD1}	...	E _{CDn}
E ₁	0	u _{1N}	...	0	0	q _{1N}	v _{1N}	0	...	0
E ₂	0	0	...	0	0	q _{2N}	0	v _{2N}	...	0
...
E _{n+1}	0	0	...	0	u _{(n+1)N}	q _{(n+1)N}	0	0	...	v _{(n+1)N}
E _{SL}	0	0	...	0	1	0	0	0	...	0
E _{FF}	0	0	...	0	0	1	0	0	...	0
E _{CD}	0	0	...	0	0	0	1	0	...	0
E _{CD1}	0	0	...	0	0	0	0	1	...	0
...
E _{CDn}	0	0	...	0	0	0	0	0	...	1

Figure 8. Modified transition probability matrix

The optimal changes of initial inspection program can be founded by analysis of new information realised after discovering of fatigue crack. Discovery of fatigue crack can give us additional observation of fatigue crack possible trajectory and, as a result, more precise estimate of parameter θ . In simplest case we can assume that now we have observation of two realizations of fatigue crack, but really all depends on both the technology of inspection and algorithm of its result analysis. This is subject of special investigation.

Thus, there are n possibilities to switch to the new inspection program, generating a set of $(n + 1)$ realizations (or scenarios) of the random inspection program, $\{IP^0, IP^1, IP^2, \dots, IP^n\}$. Let $b = \{b_0, b_1, b_2, \dots, b_n\}$ is a vector of corresponding probabilities: b_i is a probability to discover a crack during i^{th} inspection in accordance with initial program, $i = 1, \dots, n$, b_0 is probability of realization of initial inspection program IP^0 (it is a probability of non-discovery of any crack at any first n inspections or probability to be absorbed in states SL, FF or CD in accordance with the initial inspection program)

$$b_i = B_N IP^0(1, 3 + i), i = 1, \dots, n, b_0 = 1 - \sum_{i=1}^n b_i. \tag{5}$$

In considered in section 2 example : $b_1 = B_N IP^0(1, 4)$, $b_2 = B_N IP^0(1, 5)$. The total failure probability of the random inspection program can be presented as a sum of at least one aircraft failure probabilities of all scenarios multiplied by the probabilities of these scenarios to realize:

$$p_f = p_{f0N} + \sum_{i=1}^n (b_i \cdot (1 - (1 - p_{fi})^{N-1})), \tag{6}$$

where p_{f0N} is failure probability of at least one aircraft in park of N aircraft with the service in accordance with initial inspection program; p_{fi} , $i = 1, \dots, n$, is a probability of failure of one aircraft with the inspection program chosen after crack discovery at i -th inspection of initial inspection program.

Let us note, that the new inspection program is implemented for every of $(N-1)$ aircraft with independent service (this mean that now after discovery of any new fatigue crack in any of $(N-1)$ aircraft

the program of inspection of others aircraft will not be changed). The value of p_{fi} is defined by equation (3) but using vector $a=(0,\dots,0,1,0,\dots,0)$, where “1” is for the $(i+1)$ -th state of the new MC, corresponding to the discovery of fatigue crack at the i -th inspection of initial inspection program. In considered in section 2 example: $p_{f0} = B_N IP^0(1,2)$, $p_{f1} = B_1 IP^1(2,2)$ and $p_{f2} = B_1 IP^2(3,2)$. (Remind, list of transient states for IP^1 is: $E_1, EE_3, EE_4, EE_5, EE_6$; for IP^2 it is E_1, E_2, EE_5, EE_6 . List of absorbing states is the same in both cases : SL, FF and CD).

4. Inspection Program Development

Usually in Aircraft Design Bureau (ADB) documents the sequence (t_1, \dots, t_n) is defined by equation $t_i = t_1 + (i-1)(t_{SL} - t_1) / n$, $i = 1, 2, \dots, n+1$, with specific choice of t_1 . Then we should choose only t_1 and n . Just now for simplicity purpose we put $t_1 = t_{SL} / (n+1)$ (in general case t_1 can be chosen, for example, as parameter-free p-bound for T_c [1], or we can try to get minimum of expectation value of n at fixed required reliability, etc). Here we consider only this ADB simple rule. But this corresponds not only to the development of inspection program without control but and to correction of initial inspection program (and really, to the development of new inspection program with new “initial” information) after discovery of some fatigue crack. The difference is only in “initial” state and in the distribution of parameter estimate, because now we have observation of trajectory of at least two fatigue cracks. (In simplest case of one-dimensional unknown parameter we can assume that now we have sample of two observations of r.v. with the same cdf).

For the only occurring once choice of inspection number the probability of failure will be function of θ and n . We denote it by $p_f(\theta, n)$. Probability $p_f(\theta, n)$ can be non-monotonous function of n if at increasing of n relocation of inspection time moments takes place. But we consider only such strategies of the choice of the sequence of inspection time moment $\{t_i, i = 0, 1, 2, \dots, n\}$ that for all $\theta \in \Theta_0$ and for enough small ε there is minimal inspection number n such that $p_f(\theta, k) \leq \varepsilon$, for all $k \geq n$, $k = 1, 2, \dots$ and $p_f(\theta, n)$ monotonously decreases if n increases beyond of this value. This n is defined by equation:

$$n(\theta, \varepsilon) = \min(k : p_f(\theta, k) \leq \varepsilon \text{ for all } k \geq n, k = 1, 2, \dots). \tag{7}$$

For the case when $p_f(\theta, n)$ is monotonous function of n a schematic diagram of the solution of the equation $p_f(\theta, n) = \varepsilon$ and calculation of the function $n(\theta, \varepsilon)$ is shown on Figure 9.

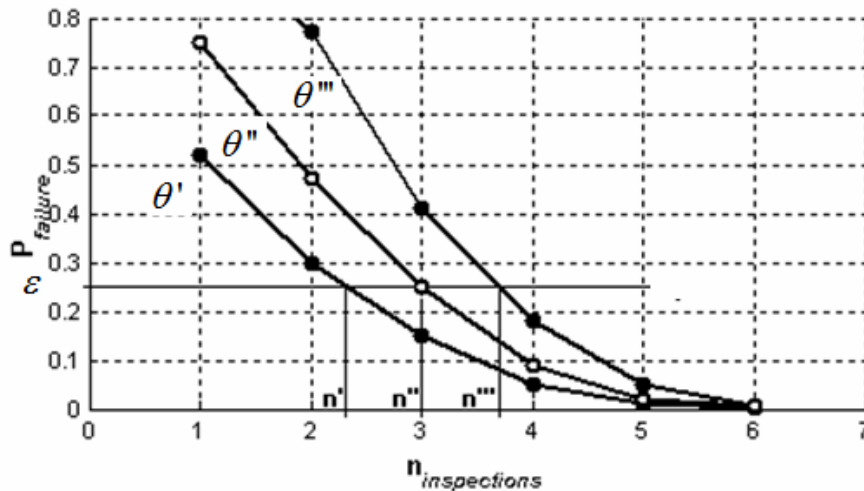

Figure 9. Choice of number of inspections as function of allowed failure probability for different parameter θ

But a true value of θ is unknown. Only observation of its estimate, a random variable $\hat{\theta}$, is known. So $\hat{n} = n(\hat{\theta}, \varepsilon)$ and $\hat{p}_f = p_f(\theta, \hat{n})$ are random variables also.

Let us define the random variable

$$\hat{p}_{f0} = \begin{cases} p_f(\theta, \hat{n}), & \hat{\theta} \in \Theta_0, \\ 0, & \theta \notin \Theta_0. \end{cases} \tag{8}$$

For this type of strategy (algorithm of choice of n) the mean probability of fatigue failure $w(\theta, \varepsilon) = E_{\theta}(\hat{p}_{f0})$ is a function of θ and ε . If for limited t_{SL} it has a maximum, depending on ε then the choice of maximal value of $\varepsilon = \varepsilon^*$ for which $w^* = \max_{\theta} w(\theta, \varepsilon) \leq 1 - R$, where R is required reliability, and the strategy, which defines the inspection number $n = n(\hat{\theta}, \varepsilon^*)$ is the choice of such strategy (decision function) for which required reliability R is provided independently of unknown θ . (Remark. The same approach can be used for any other strategy for nomination the sequence of inspection time moments if this strategy is defined by some parameter, ν , which instead of n defines the sequence $(t_1, \dots, t_{n(\nu)})$ in such a way that for all $\theta \in \Theta_0$ and for any $\varepsilon, 0 < \varepsilon < 1$, there is parameter, ν , defined by equation (7), where ν should be read instead of n . For example, we can choose intervals between inspections under condition of constancy of conditional probability of failure in every interval under condition that in previous intervals fatigue crack did not appear).

Control IP is defined by vector (n, n_1, \dots, n_n) , where n is inspection number for initial program (it is chosen for “initial” program in accordance with equation (6)), $n_i, i = 1, \dots, n$, is an inspection number for every “second part” of operation (after the discovery of fatigue crack at i -th inspection of initial IP). If, in the simplest case, for every “absorbing state” CDi, we chose n_i again under condition that in remaining operating time the probability of failure p_{fi} does not exceed some fixed value, which is some known function of $\varepsilon, \varepsilon_n(\varepsilon)$, then the total probability of failure, p_f , will be only function of θ and $\varepsilon, p_{f\varepsilon}(\theta, \varepsilon)$. Remind, that following calculation of $E_{\theta}(p_{f\varepsilon}(\hat{\theta}, \varepsilon))$ this time should be made using not only the cdf of initial estimate, $\hat{\theta}$, but taking into account that this estimate is corrected after the discovery of fatigue crack. The procedure of this correction is a subject of special investigation. Here we underline only that the core of this problem solution is the solution for the simple IP of the equation (6), in which instead of $p_f(\theta, n)$ should be used

$$p_{fi} = a_i B_i b \tag{9}$$

with the vector $a_i = (0, \dots, 0, 1, 0, \dots)$, where unit is for $(i+1)$ -th component but again vector column $b = (0, 1, 0)'$. So in this paper we consider only numerical example of the choice of n for the simple IP [3].

5. Numerical examples

It is clear that before calculation of p_f and choice of inspection program we should made calculation of $p_{f0N}, p_{fi}, i = 1, \dots, n, p_{fi}, i = 1, \dots, n$, and $b = \{b_0, b_1, b_2, \dots, b_n\}$. As it was told already, here we consider only calculation of p_{f0N} for $N=1$ and choice of initial number of inspections. Calculation after discovery fatigue crack should be made in similar way (should be changed only a priori distribution (vector a) and distribution of parameter estimate because now we have observations of two fatigue cracks.

As it was tolled already also, we suppose that random variables $X = \log(Q)$ and $Y = \log(C_c)$ have normal distributions with unknown mean values θ_{0X}, θ_{0Y} and known both standard deviations and correlation coefficient, $\theta_{1X}, \theta_{1Y}, r$. In considered example we suppose to have event $\hat{\theta} \notin \Theta_0$ and we will return the considered project to redesign if required number of inspections exceeds $n_R=5$ or value of

$\hat{t}_c = C_c / Q$, estimate of mean time to failure, $E(T_c)$, using result of initial full scale fatigue test, lesser than $t_{SL} = 40000$ (flights). For this examples we assume that only one full-scale test (before corresponding aircraft park service beginning) had been performed and we have observation of just one single crack growth and corresponding estimates: $\hat{\theta}_{0X} = \ln Q = -8.588527$, $\hat{\theta}_{0Y} = \ln C_c = 1.905525$. These estimate we use later for the choice of initial inspection number. But first, using Monte Carlo method for modelling of possible another estimates, of we make calculation of the surface $w(\theta, \varepsilon) = E_\theta(\hat{p}_{f0})$ for all parameters in some set of $\theta = (\theta_{0X}, \theta_{0Y})$ in the closeness of the point $(\hat{\theta}_{0X}, \hat{\theta}_{0Y})$. On the Figure 10 the calculation results of $w(\theta, \varepsilon) = E_\theta(\hat{p}_{f0})$ for $\varepsilon = 0.001$ is presented (in this examples we use inspection program with special choice of t_1 and evenly distributed time moments between t_1 and t_{SL} ; the time moment of the first inspection is defined by equation $\ln t_1 = \ln t_{SL} - 5 \cdot \theta_{1X}$; the detectable and critical crack sizes are $a_d = 20mm$, $a_c = 237.84mm$). Complex form of the function $w(\theta, \varepsilon)$ is defined by the fact that $p_f(\theta, n)$ might be non-monotonous function of n . For relatively small n , $p_f(\theta, n)$ can grow with the increase of n . The reason of such “strange” effect comes from the fact of inspection time moments relocation with the change of n .

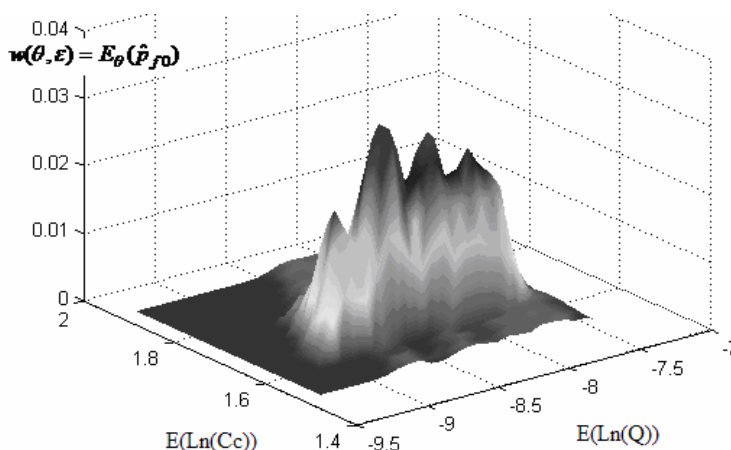

Figure 10. Function $w(\theta, \varepsilon) = E_\theta(\hat{p}_{f0})$ for $\varepsilon = 0.001$

This time the maximum values of the function $w(\theta, \varepsilon)$ are equal to 0.030990. If we repeat this calculations using various values of failure probability ε we will get a set of “surfaces” $w(\theta, \varepsilon) = E_\theta(\hat{p}_{f0})$ and function $w^*(\varepsilon) = \max_\theta w(\theta, \varepsilon)$, see Figure 11.

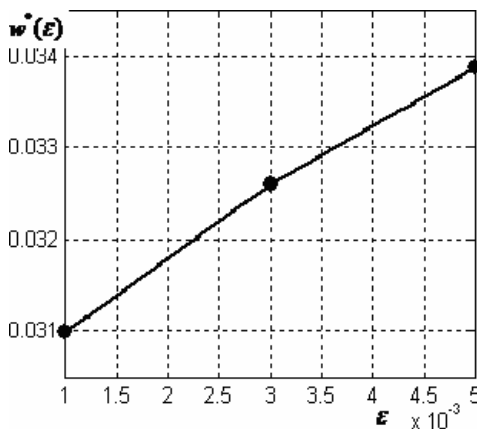

Figure 11. Numerical example: The function $w^*(\varepsilon)$

Using this function we see, that to ensure the probability of failure not exceeding, for example, $w^* = 0.0326$ for the choice of n^* , required number of inspections for our inspection program, we should use $\varepsilon^* = 0.003$ (it is worth to mention that w^* is ten times higher than ε^* !). Remind, that $n^* = n(\hat{\theta}, \varepsilon^*) = \min(k : p_f(\hat{\theta}, k) \leq \varepsilon^* \text{ for all } k \geq n, k = 1, 2, \dots)$. In our example $\theta = \hat{\theta} = (\hat{\theta}_{0X}, \hat{\theta}_{0Y}) = (-8.588527, 1.905525)$ and the required number of inspections $n^* = 5$ (it is worth to mention that $n(\hat{\theta}, 0.0326) = 4$).

For control IP similar calculations should be made for every quasi absorbing state (with specific cdf of parameter estimates). Then corresponding p_{f0N} and vector $b = \{b_0, b_1, b_2, \dots, b_n\}$ should be calculated. And again remind that all these calculation should be made for all parameters in some set of $\theta = (\theta_{0X}, \theta_{0Y})$ in the closeness of the point $(\hat{\theta}_{0X}, \hat{\theta}_{0Y})$.

6. Conclusions

It is shown that using Markov chains theory a development of controlled inspection program of fatigue-pron airframe can be made. Using of minimax approach we can provide required reliability of the fleet and in the case when we do not know true parameter of fatigue crack growth but only observation of limited number fatigue cracks in approval full-scale airframe fatigue test. The offered mathematical model allows taking into account the observation of fatigue crack in operation during planned inspection also.

References

1. Paramonov, Yu.M. P-set function application for specified life nomination and inspection program development. In: "*Probabilistic Analysis of Rare Events: Theory and Problems of Safety, Insurance and Ruin. Proceedings of international conference. Jurmala, Latvia. June 28 - July 3, 1999*". Riga: RAU, 1999, pp. 202-208.
2. Paramonov, Yu.M. and Paramonova, A.Yu. Inspection program development by the use of approval test results, *International journal of reliability, quality and safety engineering*, Vol. 7, No 4, 2000, pp. 301-308.
3. Paramonov, Yu., Kuznetsov, A. Inspection program development for fatigue crack growth model with two random parameters, *Aviation*, Vol.12, No 2, 2008, pp. 33-40.
4. Yang, J.N., Manning, S.D. Distribution of equivalent initial flow size. In: *Proceedings of annual reliability and maintainability symposium*. January 1980, pp. 112-120.
5. Yang, J.N. Statistical crack growth in durability and damage tolerant analyses. In: *Proc. AIAA/ASME/ASCE/AHS 22nd. Structures, Structural Dynamics and Materials Conference*, 1980, pp. 38-44