

INFORMATION FUSION MULTIPLE-MODELS QUALITY DEFINITION AND ESTIMATION

Boris V. Sokolov^(a), Vyacheslav A. Zelentsov^(a), Rafael M. Yusupov^(a), Yuri A. Merkurjev^(b)

^(a)St. Petersburg Institute for Informatics and Automation of the Russian Academy of Sciences (SPIIRAS),
St. Petersburg, Russia

^(b)Riga Technical University, Kalku street 1, Riga, Latvia

^(a) sokol@ias.spb.su, v.a.zelentsov@gmail.com, spiiiran@ias.spb.su ^(b) merkur@itl.rtu.lv

ABSTRACT

Nowadays the theory, methods and techniques concerning the application of mathematical models are wide used. Nevertheless such problems as a quality estimation of multi-criteria models, an analysis and classification of applied models, as well as justified selection of task-oriented models are still not well investigated. The importance of the problem increases when a research object is described not via a single model, but with a set or a complex of multiple-models including models from different classes or combined models such as combined analytical–simulation models, logical-algebraic ones, etc. Aforementioned problems are the primary research objects of the quality control theory of mathematical models and multiple-model complexes. The description of main elements of this theory is the primary goal of the paper. The implementation of this theory is connected with the information fusion multiple-models area

Keywords: multiple-model description and estimation, analysis and classification of models, justified selection of applied task-oriented models, quality control of model complexes.

1. INTRODUCTION

One of the most important factors of scientific and technological revolution is the introduction of automatic systems and informational systems (AS and IS) in all fields of human activity (Yusupov and Zabolotskii 2000). Both in the field of industrial manufacturing and in the informational sphere, the role and significance of such a notion as quality is constantly growing and is being developed under the influence of novel technologies and market needs. In the last decades, the problems connected with testing the quality of products have become the subject of intensive investigations conducted in such a new scientific branch as quality science. One of the main branches of this science is qualimetry, which is devoted to the development of methodological backgrounds for the quantitative estimation of product quality (Azgal'dov 1982).

The central concept of both quality science and qualimetry is the concept of quality, which, according to the ISO 8402-2000 international standard, means a totality of characteristics of an object that determine its capability to satisfy the established or supposed requirements (Azgal'dov 1982; Andrianov and Subetto 1990). In the field of designing and applying new information technologies, the investigations devoted to estimation of the product quality have been long conducted. The results of these investigations have been reflected in the international standards and our GOST (Lipaev 2001). For example, the international standard ISO 9126:1991 "Information technology. Evaluation of software products. Quality characteristics and a manual for their application" (Lipaev 2001; International Standards ISO 9000 and 10000 for the Quality System: Versions of 1994 1995) and the subsequent standards (ISO 9126:1--4, ISO 14598-1--6: 1998--2000) contain models, indices, criteria, and metrics of the quality of software tools and products (Lipaev 2001).

The analysis of the results obtained in this field has shown that, by now, there exist methodological tools that allow one to evaluate the quality of a computer model or a computer program (Lipaev 2001; International Standards ISO 9000 and 10000 for the Quality System: Versions of 1994 1995). Therefore, in the modern conditions, the development of tools for evaluating the quality of methods, models, algorithms, and methodologies at earlier stages of modeling original objects is very topical.

It is worth noting that, in the field of investigating the quality of models, many scientific and practical results connected both with qualitative and quantitative estimation and analysis of the properties of models (Samarskii and Mikhailov 2001; Merkurjeva, Merkurjev and Vanmaele 2011) and the choice (synthesis) of models have already been obtained (Krishans, Mutule, Merkurjev and Oleinikova 2011; Savin 2000; Prangishvili 2000). For different application domains, specific theories and technologies of modeling have been designed. In addition, a large number of bases of models and poly-model systems have been developed which are being widely used in practical investigations (Aframchuk, Vavilov,

Emel'yanov et al. 1998; Ivanov and Sokolov 2010; Vasil'ev 2001; Sethi and Thompson 2006).

Together with this, under the presence of a large number of various models, the problems of substantiated choice of models, their comparison, arrangement, and comparison of different technologies of modeling are still unsolved (Aframchuk, Vavilov, Emel'yanov et al. 1998).

Moreover, under the modern conditions, there is an urgent need in designing information technologies that can be used without designers as free as it can be done for the corresponding software products (Val'kman 1996). First of all, to solve all specified problems, the theoretical backgrounds that allow one to solve problems of evaluating and analyzing the quality of models and poly-model (multiple-model) systems have to be developed. The results of this investigation are very important for substantiation choice of structure of multiple-model complexes in different areas. In our case we use these results for structure-functional synthesis of multimodal interfaces in man-machine systems (Krishans, Mutule, Merkurjev and Oleinikova 2011; Savin 2000; Prangishvili 2000; Aframchuk, Vavilov, Emel'yanov, et al., 1998; Ivanov and Sokolov 2010; Vasil'ev 2001; Sethi and Thompson 2006; Val'kman 1996; Pavlovskii 2000). The main problem of these systems is connected with information fusions from different types of input devices (an eye-gaze, a gaze-speech, a manual-gaze-speech input devices, for example). In our paper we propose the methodological backgrounds of the solution of the problem of qualimetry of models employed in integration of data and knowledge from multi-model interfaces in man-machine systems.

2. THE MAIN TASKS AND RESULTS OF INVESTIGATION

2.1. Problem A. Investigation overview and related work

The analysis of the material presented above has shown that, regrettably, in modern conditions, the problems of estimating the quality of models, analyzing, ranking their classes, reliably synthesizing new models, or choosing existing models that are preferable for solving particular applied problems are still unsolved. The topicality of this problem grows when the investigated object is described by a poly-model system, which may contain diverse and combined structures estimated by their own indices (Aframchuk, Vavilov, Emel'yanov et al. 1998; Sethi and Thompson 2006; Pavlovskii 2000; Moiseev 1981; Tyatyushkin 2003). Additional complexity arises when we should take into account the *time factor*. This is mainly true for original objects that, due to some reasons (objective, subjective, internal, external, etc.), have structural dynamics (Okhtilev, Sokolov, Yusupov 2006). Under these conditions, to provide that a model preserves its adequacy, it is necessary to adapt its parameters and structures to changeable conditions.

For this purpose, in advance, at the stage of synthesizing the model, it is necessary to introduce in the composition of its parameters and structures additional elements (redundancy). In the further application, these elements will allow one to control the model quality and to reduce the sensitivity of the model and the corresponding quality indices to variations in the composition, structure, and content of the source data. However, in our opinion, to constructively solve the general problem of evaluating and controlling the quality of models (of choosing the most preferable variants), first of all, we should investigate the following complexes of problems: *to describe, classify, and choose a system of indices that evaluates the quality of models and poly-model systems; to develop a generalized description (macrodescription) of various classes of models (macromodels) that allow one, first, to establish interrelations and correspondences between the types and kinds of models, and, second, to compare and rank them, using various metrics; to develop combined methods for estimating quality indices of models (poly-model systems) given by numerical and non-numerical (nominal and ordinal) scales; to develop methods and algorithms for solving problems of multicriterial analysis, ordering, choice of the most preferable models (poly-model systems), and control of their quality; and to develop the methodological backgrounds of the solutions of problems of multicriterial analysis and synthesis of technologies of integrated (system) modeling of complex objects.*

In our opinion, the specified problems and the methodological backgrounds for their solution, supplemented by the development of the conceptual and methodological base, can be regarded as components of a new applied theory, which will be called in what follows *qualimetry of models (modelmetry)* (Okhtilev, Sokolov, Yusupov 2006). Consider in detail the most important aspects of the specified problems of qualimetry of models and poly-model systems.

The concept of model is widely applicable in natural human languages and is a general scientific term. It is characterized by polysemy that is brightly expressed and reflects different meanings of this concept depending on applications and contexts. At present, there are several hundred definitions of the concept of a model and modeling (Peregudov and Tarrasenko 1989). Let us present some of them (Samarskii and Mikhailov 2001; Sethi and Thompson 2006; Pavlovskii 2000; *Reliability and Efficiency in Engineering: Handbook* 1988; Rostovtsev Yu.G. and Yusupov R.M. 1991). For example, a model is a system whose investigation is a tool for obtaining information about another system; a model is a method of knowledge existence; a model is a multiple-system map of the original object that, together with absolutely true content, contains conditionally true and false content, which reveals itself in the process of its creation and practical use; modeling is one of the stages of cognitive activity of a subject, involving the development (choice)

of a model, conduction of investigations with its help, obtaining and analyzing the results, production of recommendations on the further activity of the subject, and estimation of the quality of the model itself as applied to the solved problem and taking into account specific conditions.

The analysis of the listed definitions implies that each correctly designed model contains objective truth (i.e., to some extent, it correctly reflects the original object) (Peregudov and Tarrasenko 1989; *Reliability and Efficiency in Engineering: Handbook* 1988). Together with this, because of the finiteness of the designed (applied) model (a limited number of elements and relations that describe objects belonging to infinitely diverse reality) and limited resources (temporal, financial, and material) supplied for modeling, the model always reflects the original object in a simplified and approximate way. However, the human experience testifies that these specific features of a model are admissible and do not oppose the solution of problems that are faced by subjects. In the course of modeling, it is advisable to distinguish the following basic elements and relations: first, a subject or subjects ($S_{<>}^m$), an original object ($Ob_{<>}^{op}$), model-object ($Ob_{<>}^m$), an environment ($CP_{<>}^m$) in which the modeling is performed; and, second, binary relations between the listed elements $R_{<1>}(Ob_{<>}^{op}, S_{<>}^m)$, $R_{<2>}(S_{<>}^m, Ob_{<>}^m)$, $R_{<3>}(Ob_{<>}^{op}, Ob_{<>}^m)$, $R_{<4>}(CP_{<>}^m, Ob_{<>}^{op})$, $R_{<5>}(CP_{<>}^m, Ob_{<>}^m)$, and $R_{<6>}(CP_{<>}^m, S_{<>}^m)$. The subscripts "<>" mean the personal names of objects (subjects) and relations (Rostovtsev and Yusupov 1991). Note that, in what follows, subjects of modeling mean the following classes of social subjects: decision makers (DM); persons that substantiate the decisions (PSD); experts; persons that use the models; and persons who design the models. Figure 1 presents possible variants of the interrelation between the listed elements and relations between them.

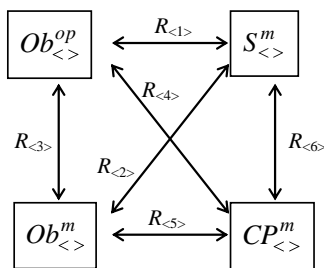

Figure 1: All possible interrelations of objects and subjects of modeling

It is worth noting that one of the main specific features of original objects (real or abstract) is their exceptional complexity (Prangishvili 2000; Aframchuk, Vavilov, Emel'yanov et al. 1998) that reveals itself in

the form of *structural complexity*, *complexity of functioning*, *complexity of the choice of behavior*, and *complexity of development*. Therefore, to describe such objects, we should use several models, rather than a unique model. In other words, we should perform *system modeling* (polymodel description of the application domain) (Aframchuk, Vavilov, Emel'yanov et al. 1998). Another specific feature of the modern stage of development of methods and tools of abstract modeling consists in considerable intensification of works in automation of this process and, first of all, the phase connected with the design of a computer model (Krishans, Mutule, Merkurjev and Oleinikova 2011; Aframchuk, Vavilov, Emel'yanov et al. 1998; Sethi and Thompson 2006). Moreover, within the framework of new information technologies based on the concepts of knowledge bases, the concept of "model" has considerably extended the limits of its application - from the field of passive informational resources to the field of active ones. Under these conditions, algorithms that are elements of procedural knowledge turn into operating environments that provide the solution of problems by a subject in the language of models. The most important components of the conceptual base of qualimetry of models and poly-model systems are their properties. Therefore, we briefly describe the main properties of models that should first be evaluated in their comparison and choice.

1. *Adequacy* (from Latin *adaequatus*, which means equated, completely suitable, or comparable). The model should possess the specified property relative to certain aspects of the original object. It is obvious that, in practice, we should say about adequacy in some sense, rather than about complete adequacy. As was mentioned above, for complex systems (original objects), a single model may reflect a side or an aspect of the prototype. Therefore, the concept of adequacy does not exist in general. We may say only about the adequacy of reflection of certain properties. For a poly-model system, we can pose the problem of achievement of adequacy in a broader sense that encompasses various features of the prototype. However, in all cases, the adequacy of the model (poly-model system) should be evaluated taking into account the degree to which it satisfies the goal of modeling (goals of the subject).

We distinguish *qualitative adequacy*, i.e., the reflection of certain qualitative properties of the original object with the help of the model, and *quantitative adequacy*, which means the reproduction of numerical characteristics of the prototype with certain accuracy. For this purpose, various types of metrics are introduced (Ivanov, Sokolov and Kaeschel 2010; Aven, Oslon and Muchnik 1988).

Because of particular significance of this property of models and poly-model systems in the general structure of the generated conceptual base of qualimetry of models, we consider in more detail possible approaches to the quantitative estimation of these characteristics in Section 4. Let us consider other indices.

2. *Simplicity and optimality of the model (poly-model system)*. The property of adequacy is directly associated with the properties of simplicity and optimality of the model. Indeed, sometimes, to achieve the required degree of adequacy, we should essentially complicate the model. On the other hand, if we can choose different models that have approximately the same adequacy, it is advisable to use the simplest model. This property becomes very topical under optimal choice of the structure of a poly-model system. In this case, the adequacy of modeling is determined by not only the properties of each model, but also the characteristics of their interaction. In (Peschel 1981, 1978; Polyak 1971), which are devoted to the general theory of modeling complex systems, a number of principles, rules, and methods that provide the correct transition from a formal description $Ob_{<>}^{op}$ to the scheme of modeling (computer program) are found.

3. *The flexibility (adaptability) of models* assumes that parameters and structures that can vary in given ranges are introduced in the composition of models in order to achieve the goals of modeling.

4. *Universality and task orientation of models*. Numerous investigations directed to the search for the specified compromise have shown that, at present, the development of universal models $Ob_{<>}^{op}$ directed to a broad application domain result in a difficult-to-solve problem. It is advisable to design models specialized relative to an admissible class of modeled objects and universal with respect to a list of supported functions.

Among other properties of models, which have to first be investigated in the framework of qualimetry, we should distinguish reliability, unification, simplicity, openness and accessibility, intelligence, the efficiency of computer implementation, complexity, identifiability, stability, sensibility, observability of models, their invariance, and self-organization and self-learning (Aframchuk, Vavilov, Emel'yanov et al. 1998; Kalinin, Sokolov 1985).

It was mentioned above that different properties of models that describe original objects $Ob_{<>}^{op}$ are evaluated and analyzed in the course of system modeling (Figure 2), which is one of the types of purposeful processes (*Reliability and Efficiency in Engineering: Handbook* 1988). Therefore, within the framework of qualimetry of models, it is advisable to consider two particular lines of investigation that encompass both the problems of estimating and analyzing the quality of different techniques of modeling $Ob_{<>}^{op}$ and the problems of choosing variants of their optimal organization. Figure 2 presents a typical aggregative technique for conducting system (integrated) modeling as an example (Aframchuk, Vavilov, Emel'yanov et al. 1998). In this figure, the following notation is accepted: 1, for theoretical investigations; 2, for methods of structural and behavior analysis; 3, for analytical investigations of models, 4, for designing models (poly-model systems); 5, for

development of a modeling algorithm; 6, for designing a computer model; 7, for simulation investigations; and 8, for the representation and interactive analysis of the results of modeling. As applied to different types of $Ob_{<>}^{op}$ different classes of employed models, this scheme may be considerably complicated. For example, in the solution of problems of synthesizing the structures of complex $Ob_{<>}^{op}$, at present, analytical and simulation models that describe various aspects of the specified problems in necessary details are widely applicable (Tsvirkun and Akinfiev 1993). In so doing, several scenarios (procedures and techniques) may be proposed for arranging and conducting integrated modeling, which may be different in the methods of generating admissible alternative solutions, in the rules for testing constraints given in an analytical or algorithmic form, and in the methods of transition from one step of interactive restriction of the set of admissible alternatives to another.

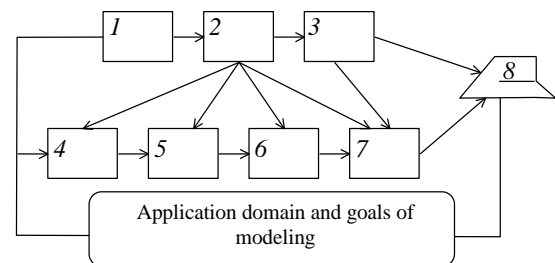

Figure 2: The technology of system modeling

The analysis of results of numerous investigations has shown that joint use of diverse models in the framework of multiple-model systems allows one to improve the flexibility and adaptability of the simulation system (SS), as well as to compensate the drawbacks of one class of models by the advantages of the other (Aframchuk, Vavilov, Emel'yanov et al. 1998; Sethi and Thompson 2006; *Reliability and Efficiency in Engineering: Handbook* 1988; Tsvirkun and Akinfiev 1993). Moreover, investigating problems of analyzing and synthesizing the structures $Ob_{<>}^{op}$ in the framework of each of the listed classes of models, the subjects of modeling may use simultaneously and in parallel several methods and algorithms different in computational complexity (*International Standards ISO 9000 and 10000 for the Quality System: Versions of 1994 1995*; Savin 2000; Aframchuk, Vavilov, Emel'yanov et al. 1998).

On the whole, each variant of implementation of the technique of system modeling is characterized by its own time cost, the expenditure of different types of resources, and by final results (effects). In these conditions, the problems of evaluating and choosing the best variants are of great interest (*Reliability and Efficiency in Engineering: Handbook* 1988).

2.2. Problem B. The results of investigations

In the solution of problems of modeling of complex objects $Ob_{<>}^{op}$, the problems of providing a required adequacy of the results and controlling the quality of models and the modeling processes is of special importance. It is obvious that, using the model $Ob_{<>}^m$ in practical investigations, we should evaluate its adequacy each time relative to $Ob_{<>}^{op}$. The reasons for inadequacy may be inexact source prerequisites in determining the type and structure of the models, measurement errors in testing, computational errors in processing sensor data, etc. (Yusupov 1977). The use of inadequate models may result in considerable economic loss, emergency situations, and failure to execute tasks posed for a real system.

For definiteness, following (Kalinin, Sokolov 1985; Rostovtsev and Yusupov 1991), we consider two classes of modeled systems. By the *first class*, we refer to those systems with which it is possible to conduct experiments and to obtain the values of some characteristics by measuring.

Figure 3 presents the generalized technique for estimating and controlling the quality of models of objects of the first class.

In this figure, we take the following notation: 1, for forming the goals of functioning of $Ob_{<>}^{op}$; 2, for determination of input actions; 3, for setting goals of modeling; 4, for the modeled system (objects $Ob_{<>}^{op}$) of the first class; 5, for the model ($Ob_{<\theta>}^m$) of the investigated system $Ob_{<>}^{op}$; 6, for the estimation of the quality of a model (poly-model system); 7, for controlling the quality of models; 8, for controlling the parameters of models; 9, for controlling the structures of models; and 10, for changing the concept of model description.

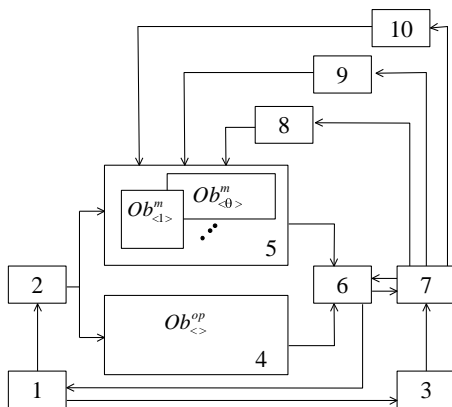

Figure 3: The generalized technique of estimation and control of the quality of models of the first class

All technical systems and complexes working in an autonomous mode are examples of systems of the first class.

We refer to the *second class* of modeled systems, for which it is impossible to conduct experiments (according to the technique presented in Figure 3 and to receive the required characteristics. Large-scale economic and social systems and complex technical systems that function under essential uncertainty of the effect of the external environment are examples of these systems. The human factor plays an important role in these systems (organization structures). Consider the variants of evaluating the adequacy of $Ob_{<>}^m$ for the mentioned systems. We assume that we have a metric space of mathematical patterns that describes $Ob_{<>}^{op}$ and $Ob_{<>}^m$. Then, it is advisable to use the distance $\rho(Ob_{<>}^{op}, Ob_{<>}^m)$ that has to satisfy the axioms of a metric (Yusupov 1977) as the proximity measure between the object and model. In the ideal situation, the proximity measure must be zero. However, in practical cases, because of a number of reasons (the principal difference between $Ob_{<>}^m$ and $Ob_{<>}^{op}$), the uncertainty of source data, measurement and computational errors, etc.), the probability of the equality

$$\rho(Ob_{<>}^{op}, Ob_{<>}^m) = 0$$

is close to zero. Therefore, a real adequacy condition must have the form

$$\rho(Ob_{<>}^{op}, Ob_{<>}^m) \leq \varepsilon, \quad \varepsilon > 0.$$

The first condition, which has a purely theoretical value, is called the condition of absolute adequacy, and the second one is called ε -adequacy. We also note that, in the course of implementation of one or another technique of modeling (Figures 1, 2, and 3), as a rule, the degree ρ of adequacy decreases in the transition from one stage of modeling to another

$$\rho_1 \leq \rho_2 \leq \rho_3 \dots \rho_R = \rho,$$

where ρ_R is the adequacy measure of $Ob_{<>}^m$ at the k stage.

As applied to the first class of $Ob_{<>}^{op}$, the considered adequacy measures can be given in various forms. For example, in deterministic description of systems, the Euclidean metric, Chebyshev metric, Hamming metric, Lee metric, etc., are most frequently used (Yusupov 1977). The value of the difference of the output actions obtained in the object ($\mathbf{y}^{(0)}(t)$) and model ($\mathbf{e} = \mathbf{y}^{(0)}(t) - \mathbf{y}(t)$) is considered as the argument in the corresponding functionals. In the stochastic case, adequacy measures based on the quantitative estimation of the distance between

random samples (the first situation) obtained in the course of experiments with $Ob_{<>}^{op}$ and $Ob_{<>}^m$ and on the estimation of the distance between the statistical laws constructed based on these samples (the second situation) (Yusupov 1977) can be proposed. In addition to the mentioned approaches in giving metrics for the first situation, the set of other metrics for analytical-simulation, logical-algebraic, logical-linguistic, and combines models have recently been developed (Ivanov, Sokolov and Kaeschel 2010; Aven, Oslon and Muchnik 1988; Yusupov 1977).

The quantitative estimation of the adequacy of models $Ob_{<>}^m$ that describe systems of the second class is difficult with the use of the metrics proposed above, since, first, it requires very large resource expenditure in order to directly determine the characteristics of the form $\mathbf{y}^{(0)}$ by conducting experiments with the specified systems, and, second, in a number of situations, it is simply unrealizable (modeling of accidents, catastrophes, and military operations). Moreover, the concept of "model adequacy" itself needs to be refined. In this case, it is advisable to comment on the usefulness and fitness of the model $Ob_{<>}^m$ for solving a certain class of problems connected with $Ob_{<>}^{op}$ (Yusupov 1977; Larichev 2000; Ceany and Raiffa 1981; *Fuzzy Sets in Models of Control and Artificial Intelligence* 1986). We assume that, to describe a certain system of the second class $Ob_{<>}^{op}$, k models $M_1(\Gamma_{<p_1>})$, $M_2(\Gamma_{<p_2>})$, ..., $M_k(\Gamma_{<p_k>})$ were proposed, each of which is characterized by its structure and a set of parameters $\Gamma_{j<p_j>}$, $j = 1, \dots, k$. First, we consider the situation when the structures of models are fixed and models differ from each other by the composition of parameters whose exact values are, as a rule, not known. It is necessary to choose the most preferable model among the set of models $\{M_j(\Gamma_{<p_j>})\}$ (Yusupov 1977). In addition, we assume that the listed models are used in order to solve the problems of prediction and choice of optimal variants of functioning of the system $Ob_{<>}^{op}$ from the point of view of a given generalized efficiency index J . Assume that it is not known in advance what actual values are taken by the parameters of a real system. Thus, it is necessary to collect data about the actual behavior of the system $Ob_{<>}^{op}$ under uncertainty conditions. Consequently, we should use additional information.

Consider the simplest situation, when $Ob_{<>}^m$ depends only on a single parameter p , which takes a finite number of values, $p \in \{p_1, p_2, \dots, p_b\}$. Note that the result of functioning the real system $Ob_{<>}^{op}$ depends on

the same parameter, which takes the same values. However, it is not known in advance which actual value is taken by the parameter p in the system $Ob_{<>}^{op}$. Assume that any deviation of the parameter of the model $M_j(p_j)$ from the value of this parameter in the real object results in a "loss," which is estimated by the index J .

To solve the problem, we form Table 1, which contains the values of the efficiency index of the following form: $J_{v\mu} = J_{v\mu}(u_v, p_\mu)$, where $J_{v\mu}$ is the value of the index of u_v for the variant of functioning of $Ob_{<>}^{op}$ computed for the model $M_v(p_v)$ under the actual value of the parameter p_μ . Based on table 1, we construct table 2 of risks calculated by the formula $\Delta J_{v\mu} = |J_{vv} - J_{v\mu}|$.

In this case, the choice of the fittest model is reduced to a choice of a value of p . As an optimization criterion, we take the criterion of minimum risk

$$J' = \min_v \max_\mu \Delta J_{v\mu}$$

Table 1: The values of the efficiency indices of the form

$$J_{v\mu} = J_{v\mu}(u_v, p_\mu)$$

	p_μ			
p_v	p_1	p_2	...	p_b
p_1	J_{11}	J_{12}	...	J_{1b}
p_2	J_{21}	J_{22}	...	J_{2b}
...
p_b	J_{b1}	J_{b2}	...	J_{bb}

Table 2: The values of the risks of the form

$$\Delta J_{v\mu} = |J_{vv} - J_{v\mu}|$$

	p_μ			
p_v	p_1	p_2	...	p_b
p_1	0	ΔJ_{12}	...	ΔJ_{1b}
p_2	ΔJ_{21}	0	...	ΔJ_{2b}
...
p_b	ΔJ_{b1}	ΔJ_{b2}	...	0

If the probabilities q_1, q_2, \dots, q_b of the occurrence of the values of the parameter p : p_1, p_2, \dots, p_b are given, then an optimal strategy is the strategy that minimizes the mean risk

$$J'' = \min_v \sum_{\mu=1}^b \Delta J_{v\mu} q_\mu$$

If we consider the general case of the choice of a many-parameter model from a given set of models $\{M_j(\Gamma_{<p_j>})\}$, then it is advisable to divide the solution of this problem into the following stages. First, for each fixed model $M_j(\Gamma_{<p_j>})$, the best

combinations of the value parameters are found in accordance with the criteria proposed above; i.e., we find $M_j^* = M_j(\Gamma_{<p_j>}^*)$. As a result, we obtain k models $M_1^*, M_2^*, \dots, M_k^*$ with fixed parameters. From these models, using an analogous procedure again, we choose the best model.

In conclusion, we consider the possible variants of the calculation of the adequacy indices of models and control of their quality for the situations when only the values of parameters are changed in the system, but the structure of models remains the same.

We introduce the following sets: the set of models $\overline{\overline{M}} = \{M_1, \dots, M_\theta\}$ of an original object $Ob_{<>}^{op}$; the set of features $\overline{P}_{cs}(t) = \{\overline{P}_g^{(cs)}, g = 1, \dots, H\}$ of $Ob_{<>}^{op}$; and the set of possible variants (totalities) of the feature values $\overline{\overline{P}}_{cs}$.

In addition, assume that $AD(M_\theta, \overline{P}_{cs})$, $\theta = 1, \dots, \Theta$ is a certain given adequacy index of the model M_θ relative to $Ob_{<>}^{op}$ that is characterized by $\overline{P}_{cs}(t)$ at the time instant t .

Together with the classical axioms of a metric, the adequacy functional $AD(M_\theta, \overline{P}_{cs})$ must possess the following additional properties (Skurikhin, Zabrodskii and Kopeichenko 1989):

- (a) $AD(M_\theta, \overline{P}_{cs}) > 0, \forall M_\theta \in \overline{\overline{M}}, \overline{P}_{cs} \in \overline{\overline{P}}_{cs}$;
- (b) $AD(M_\theta, \overline{P}_{cs}^{(1)}) > AD(M_\theta, \overline{P}_{cs}^{(2)})$,

where the model M_θ more adequately describes $Ob_{<2>}^{op}$ with the set of features $\overline{P}_{cs}^{(2)}$ than $Ob_{<1>}^{op}$ with the set of features $\overline{P}_{cs}^{(1)}$;

- (c) $AD(M_{\theta_1}, \overline{P}_{cs}^{(1)}) > AD(M_{\theta_2}, \overline{P}_{cs}^{(2)})$,

where the model M_{θ_2} more adequately describes $Ob_{<1>}^{op}$ with the set of features $\overline{P}_{cs}^{(1)}$ than the model M_{θ_1} . It was supposed in relations (a)–(c) that the parameters of each model are optimally adjusted to the corresponding $Ob_{<>}^{op}$. It is worth noting that, under the action of different factors, both the parameters and structures of $Ob_{<>}^{op}$ can be changed. Therefore, in the estimation of the functionals involved in (a)–(c), it is necessary to take into account and predict the variation in the values of the parameters $\overline{P}_{cs}(t)$ characterizing $Ob_{<>}^{op}$ and the environment at each time instant, so as to temporally correct the structures and parameters of the model (poly-model system). Choosing the value of the time interval, for which we have to predict the

values of features of $Ob_{<>}^{op}$, we should find such a compromise decision that, on the one hand, provides as accurate an estimation of \overline{P}_{cs} as possible, and, on the other hand, the chosen time interval must be big enough for constructing a new model $Ob_{<>}^{op}$ and adjustment of its parameters before its operation. Moreover, the universe of events $\overline{\overline{P}}_{cs} = \overline{\overline{P}}_{cs}(t)$ that changes in time is characteristic of developing situations. Under these conditions, the approach based on interpretation of the processes of designing models and evaluating their quality by methods of modern control theory of dynamic systems with reconfigurable structure (Okhtilev, Sokolov, Yusupov 2006) is very prospective. As an example, we can consider two possible statements of the problem of controlling the quality of models (synthesis of their structure) based on the proposed dynamical interpretation of the processes occurred.

Problem A. It is required to minimize a functional that characterizes the degree of proximity of the model and $Ob_{<>}^{op}$ under the constraints on the total time of synthesizing the model and on its parameters and structures (Skurikhin, Zabrodskii and Kopeichenko 1989)

$$\begin{aligned} AD(M_\theta^{(l)}, \overline{P}_{cs}) &\rightarrow \min, \\ t_{st}(\mathbf{w}, M_\theta^{(l)}) &\leq \bar{t}_{st}, \\ M_\theta^{(l)} &\in \overline{\overline{M}}, \mathbf{w} \in W, \\ M_\theta^{(l)} &= \overline{\overline{\Phi}}(M_\theta^{(l-1)}, \mathbf{w}, \overline{P}_{cs}), l = 1, 2, \dots, \end{aligned}$$

where $AD(M_\theta^{(l)}, \overline{P}_{cs})$ is a functional that is used to estimate the degree of adequacy of the model $M_\theta^{(l)}$ relative to the object $Ob_{<>}^{op}$ characterized by the set of features from the set $\overline{P}_{cs}(t) = \{\overline{P}_g^{(cs)}, g = 1, \dots, H\}$; t_{st} is the total time of synthesizing a model with given properties; \bar{t}_{st} is the limit admissible time of synthesizing the model; $\overline{\overline{\Phi}}$ is the operator of interactive construction of the structure of the model $M_\theta^{(l)}$; l is the current iteration number; \mathbf{w} is the vector of parameters of the structural adaptation of the model; and W is the set of its admissible values.

Problem B, which is inverted to Problem A, can be represented in the following form:

$$\begin{aligned} t_{st}(\mathbf{w}, M_\theta^{(l)}) &\rightarrow \min, \\ AD(M_\theta^{(l)}, \overline{P}_{cs}) &\leq \varepsilon_2, \\ M_\theta^{(l)} &\in \overline{\overline{M}}, \mathbf{w} \in W, M_\theta^{(l)} = \overline{\overline{\Phi}}(M_\theta^{(l-1)}, \mathbf{w}, \overline{P}_{cs}), \end{aligned}$$

where ε_2 is a given constant that characterizes the admissible level of degree of adequacy of the models $Ob_{<>}^m$ of the form $M_{\theta}^{(l)}$; and $\theta \in \tilde{I} = \{1, \dots, \Theta\}$, \overline{M} is the set of possible variants of models $Ob_{<>}^m$.

From the point of view of control theory, these problems are referred to the class of problems of adaptation of the parameters and structures of objects (the models $Ob_{<>}^{op}$ are regarded as objects). The presented relations imply that, as the main criterion of the process of parametric and structural adaptation of the models $Ob_{<>}^{op}$ (or, in other words, of the control of the model quality), it is advisable to choose the condition of adequacy of models. Note that adequacy means the principal correspondence between the results of modeling and the changes and relations between $Ob_{<>}^{op}$ and the environment that takes place under real conditions, rather than the reflection of the models in all details. The main destination of the quantitative evaluation of the adequacy used at the time instant t of the model $M_{\theta}^{(l)}$ is determined by the

necessity to improve to an admissible level the *confidence degree* of the decision maker that will allow him to judge the correctness of the propositions about the real object based on the data obtained in modeling (Aframchuk, Vavilov, Emelyanov et al. 1998; Vasil'ev 2001; Okhtilev, Sokolov, Yusupov 2006; Kalinin, Sokolov 1985; Peregudov and Tarrasenko 1989; *Reliability and Efficiency in Engineering: Handbook* 1988; Rostovtsev and Yusupov 1991).

CONCLUSION

Resuming the aforementioned, we should note that, under modern conditions, it is very urgent to develop the methodological foundations of the theory of estimation and control of the quality of models or *qualimetry of models*. This theory is a part of the science of quality and can be decomposed into many particular applied directions in which the estimation of the quality of models employed in a certain application domain should be conducted.

Figure 4 presents as an example the basic elements of the theory of estimation and control of the quality of models developed recently, which are used

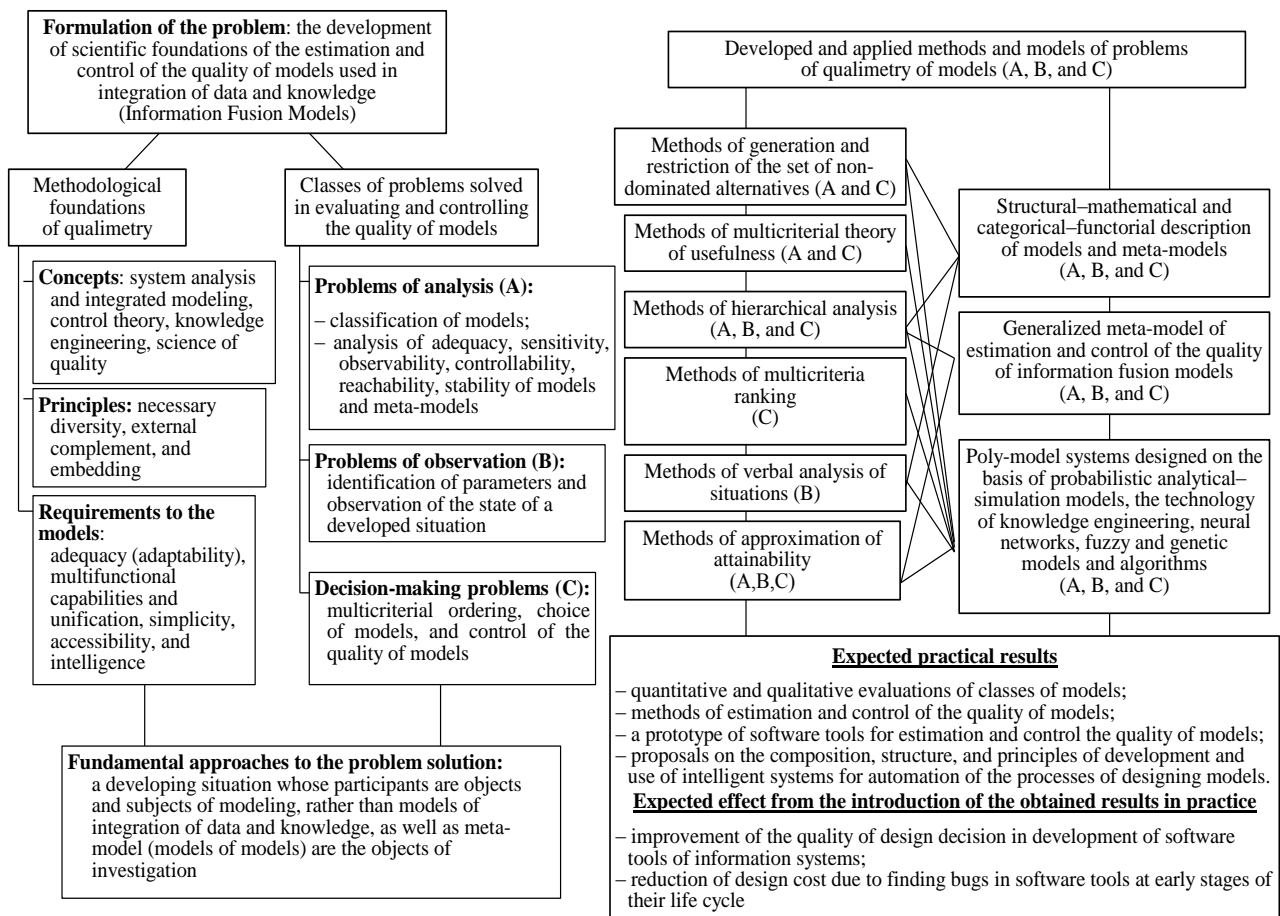

Figure 4: The methodological backgrounds of the solution of the problem of qualimetry of models employed in integration of data and knowledge

in integration of data and knowledge (Information Fusion Models) (Okhtilev, Sokolov, Yusupov 2006; Kalinin and Reznikov 1987; Yusupov 1977; Ceany and Raiffa 1981; *Fuzzy Sets in Models of Control and Artificial Intelligence* 1986). In our opinion, the development of qualimetry of models should be made in parallel in the main two lines of investigations that closely interact with each other. In the framework of the first line of investigations, the general problems based on the results obtained in solving applied problems of the theory of estimation and control of the model quality (*Reliability and Efficiency in Engineering: Handbook* 1988). It is advisable to set off the development of integrated systems for decision-making in estimation and control of the quality of models and poly-model.

ACKNOWLEDGMENT

The research described in this paper is supported by project 2.1/ELRI-184/2011/14 «Integrated Intelligent Platform for Monitoring the Cross-Border Natural-Technological Systems» as a part of the Estonia-Latvia-Russia cross border cooperation Programme within European Neighborhood and Partnership instrument 2007-2013.

REFERENCES

- Aframchuk, E.F., Vavilov, A.A., Emel'yanov S.V., et al., 1998. *Technology of System Modeling*. Emel'yanov S.V., ed. Moscow: Mashinostroenie. [in Russian].
- Andrianov, Yu.M. and Subetto, A.I., 1990. *Qualimetry in Engineering*. Leningrad: Mashinostroenie. [in Russian].
- Aven, P.O., Oslon, A.A. and Muchnik, I.B., 1988. *Functional Scaling*. Moscow: Nauka. [in Russian].
- Azgal'dov, G.G., 1982. *The theory and Practice of Estimation of the Quality of Products: Foundations of Qualimetry*. Moscow: Ekonomika. [in Russian].
- Ceany, R.L. and Raiffa, H., 1981. *Decision Making under Many Criteria: Preferences and Fillings*. Moscow: Radio i Svyaz'. [in Russian].
- Fuzzy Sets in Models of Control and Artificial Intelligence*, 1986. Pospelov, D.A., ed. Moscow: Nauka, Moscow. [in Russian].
- International Standards ISO 9000 and 10000 for the Quality System: Versions of 1994, 1995*. Moscow: Standarty. [in Russian].
- Ivanov, D.A. and Sokolov B.V., 2010. *Adaptive supply chain management*. Berlin: Springer.
- Ivanov, D.A., Sokolov, B.V., and Kaeschel, J., 2010. A multi-structural framework for adaptive supply chain planning and operation with structure dynamics considerations. *European Journal of Operation Research*, 200(2), 409-420.
- Kalinin, V.N. and Reznikov, B.A., 1987. *Systems Theory and Control Theory (Structural--Mathematical Approach)*. Leningrad: VIKI. [in Russian].
- Kalinin, V.N., Sokolov, B.V., 1985. Optimal planning of the process of interaction of moving operating objects. *International Journal of Difference Equations*, 21(5), 502-506.
- Kalinin, V.N. and Sokolov, B.V., 1995. Many-Model Approach to the Arrangement of Control Processes for Space Facilities. *Izv. Ross. Akad. Nauk, Teor. Sist. Upr.*, 1. [Comp. Syst. Sci. @34@ (1), 47 (1995)].
- Krishans Z., Mutule A., Merkurjev Y. and Oleinikova I., 2011. *Dynamic Management of Sustainable Development. Methods for Large Technical Systems*. London: Springer-Verlag.
- Larichev, O.I., 2000. *The Theory and Methods of Decision Making*. Moscow: Logos. [in Russian].
- Lipaev, V.V., 2001. *Estimation of the Quality of Products*. Moscow: ERIS. [in Russian].
- Merkuryeva, G., Merkurjev, Y. and Vanmaele, H., 2011. Simulation-Based Planning and Optimization in Multi-Echelon Supply Chains. *Simulation: Transactions of The Society for Modeling and Simulation International*. 8 (87), 698–713.
- Mesarovich, M. and Takahara, I., 1978, 1975. *General Systems Theory: Mathematical Foundations*. Moscow: Mir, Moscow, 1978. New York: Academic.
- Moiseev, N.N., 1981. *Mathematical Problems of Systems Analysis*. Moscow: Nauka. [in Russian].
- Nemirovskii, A.S. and Yudin, D.B., 1979. *The Complexity of Problems and Efficiency of Optimization Methods*. Moscow: Nauka. [in Russian].
- Okhtilev, M.Y., Sokolov, B.V., Yusupov, R.M., 2006. *Intelligent technologies of complex technical objects monitoring and structure dynamics control*. Moscow: Nauka. [in Russian].
- Pavlovskii, Yu.A., 2000. *Simulation Models and Systems*. Moscow: Fazis. [in Russian].
- Peregudov, F.I. and Tarrasenko, F.P., 1989. *Introduction to Systems Analysis*. Moscow: Vysshaya Shkola. [in Russian].
- Peschel M., 1981, 1978. *Modellbildung fur Signale und Systeme*. Moscow: Mir. Berlin: Technik.
- Polyak, Yu.G., 1971. *Probabilistic Modeling on Computers*. Moscow: Sovetskoe Radio, Moscow. [in Russian].
- Prangishvili, I.V., 2000. *System Approach and System Regularities*. Moscow: Sinteg, Moscow. [in Russian].
- Reliability and Efficiency in Engineering: Handbook*, 1988. Utkin V.F. and Kryuchkov Yu.V., ed., 3. Moscow: Mashinostroenie. [in Russian].
- Rostovtsev, Yu.G. and Yusupov R.M., 1991. The Problem of Adequacy Evaluation for Subjective-Objective Modeling. *Izv. Vuzov. Priborostr.*, 7.
- Samarskii, A.A. and Mikhailov, A.P., 2001. *Mathematical Simulation: Ideas, Methods, and Examples*. Moscow: Fizmatlit. [in Russian].

- Savin, G.I., 2000. *System Modeling of Complex Processes*. Moscow: Fazis. [in Russian].
- Sethi, S.P. and Thompson, G.L., 2006. *Optimal control theory: applications to management science and economics*. 2nd ed. Berlin: Springer.
- Skurikhin, V.I., Zabrodskii, V.A. and Kopeichenko, Yu.V., 1989. *Adaptive Control systems for Manufacturing*. Moscow: Mashinostroenie. [in Russian].
- Tsvirkun, A.D. and Akinfiyev, V.K., 1993. *The Structure of Multilevel and Large-Scale Systems (Synthesis and Planning of the Development)*. Nauka: Moscow. [in Russian].
- Tyatyushkin A.I., 2003. Many-Method Technique for Computing Optimal Control. *Izv. Ross. Akad. Nauk, Teor. Sist. Upr.*, 3 [Comp. Syst. Sci. **42** (3), 371 (2003)].
- Val'kman, Yu.R., 1996. The Problem of "Alienating" Models of Studied Objects from Their Creators in Complex Object Design, *Izv. Ross. Akad. Nauk, Teor. Sist. Upr.*, 3. [Comp. Syst. Sci. **35** (3), 487 (1996)].
- Vasil'ev, S.N., 2001. From Classical Control Problems to Intelligent Control. *Izv. Ross. Akad. Nauk, Teor. Sist. Upr.*, 1 and 2. [Comp. Syst. Sci. **40** (1, 2), 1 (2001)].
- Yusupov, R. M., 1977. *Elements of the Theory of Testing and Control of Industrial System*. Moscow: Energiya. [in Russian].
- Yusupov, R.M. and Zabolotskii V.P., 2000. *Scientific and Methodological Aspects of Informatization*. St. Petersburg: Nauka. [in Russian].

AUTHORS BIOGRAPHY

BORIS V. SOKOLOV is a deputy director of the St. Petersburg Institute for Informatics and Automation of Russian Academy of sciences. He is an author and co-author of 5 books on systems and control theory and more than 320 scientific papers. Professor B. Sokolov supervised more than 75 research and engineering projects. *Homepage: litsam.ru*

VIACHESLAV A. ZELENTSOV is professor, leading researcher, Laboratory for Information Technologies in Systems Analysis and Modeling, Head of Research Consulting Center for Space Information Technologies and Systems at SPIIRAS. Professor B. V.Zelentsov published about 180 scientific papers, supervised more than 50 research and engineering projects. He is an author of 5 teaching books.

RAFAEL M. YUSUPOV is Corresponding Member of the Russian Academy of Sciences (RAS), Doctor of Sciences (Tech.), Professor, and Director of the St. Petersburg Institute for Informatics and Automation of RAS, Honored Scientist of the Russian Federation. Research interests are in control theory, informatics, and theoretic basics of informatization and information society, and information security. He is an author of more than 350 publications.

YURI A. MERKURYEV is professor, head of the Department of Modelling and Simulation of Riga

Technical University. He earned the Dr.sc.ing. degree in 1982 in systems identification, and Dr.habil.sc.ing. degree in 1997 in systems simulation. His professional interests include methodology of discrete-event simulation, supply chain simulation and management, as well as education in the areas of simulation and logistics management. Professor Merkuryev is a corresponding member of the Latvian Academy of Sciences, president of Latvian Simulation Society, board member of the Federation of European Simulation Societies (EUROSIM), senior member of the Society for Modelling and Simulation International (SCS), and Chartered Fellow of British Computer Society. He authors more than 300 publications, including 6 books and 6 textbooks.