

A COLOURED PETRI NET MODEL FOR THE MAS SIMULATION OF URBAN ECONOMICS IN YANTAI

Roman Buil^(a), Miquel Angel Piera^(b), Egils Ginters^(c), Artis Aizstrauts^(d)

^(a,b) Universitat Autònoma de Barcelona, Department of Telecommunications and Systems Engineering, Unit of Logistics and Aeronautics, C. dels Emprius, 2, 08202, Sabadell, Barcelona, Spain

^(c,d) Sociotechnical Systems Engineering Institute of Vidzeme University of Applied Sciences, Cesu street 4, Valmiera LV-4201, Latvia

^(a)miquelangel.piera@uab.cat, ^(b)roman.buil@uab.cat, ^(c)egils.ginters@va.lv, ^(d)artis.aizstrauts@va.lv

ABSTRACT

E-governance is one area in which the use of simulation could help the decision maker to take better decisions with positive impact in the society. The Multi Agent Systems (MAS) models were already used to foster e-participation in which citizens could be involved in the design of urban policies that affects their habitat environment. Coloured Petri Net (CPN) models have been already used as a base to develop MAS models in Repast Simphony.

This paper presents the use case developed in FUPOL for Yantai, China. The model will be used to decide which policy to use in order to establish a criteria to force industries to upgrade (to reduce consumptions and pollution) or to close. Results will show how different are the closed industries during a simulation depending on the indicators weights in the cost function.

Keywords: Urban policy, urban economics, petri net, MAS simulation, e-participation

1. INTRODUCTION

Digital Simulation techniques can contribute to increase the knowledge about the possible consequences of taking some decisions or others. E-governance is one area in which the use of simulation could help the decision maker to take better decisions with positive impact in the society. A new methodology based on the transformation of Coloured Petri Net (CPN) models into Multi Agent System (MAS) models was already presented in Buil and Piera (2013) and Piera et al (2014) as part of their work in the FP7 project FUPOL.

Buil and Piera (2013) presented a causal modelling approach, which takes into consideration that actors have different skills and pre-knowledge of the complex urban system. By incorporating users' heterogeneity in non-scientific knowledge (subjective values), interests and preferences, FUPOL modelling approach contributed to overcome one of the main shortages of present policy models: citizen e-participation.

E-participation in urban decision-making means the use of ICT for enabling and strengthening citizen participation in democratic decision-making processes.

The use of ICT in e-Participation process consists on motivation and engagement of a large number of citizens through diverse modes of technical and communicative skills to ensure broader participation in the policy process, real-time qualitative and accessible information, and transparent and accountable governance.

Piera et al (2013) consider some of the difficulties in establishing verification and validation of agent based models, and proposes the use of CPN formalism to specify agent behaviour in order to check if the model looks logical and the model behaves logical. Model plausibility is used to express the conformity of the model with a priori knowledge about the process. A proof-of-concept is presented by means of a case study for testing the robustness of emergent patterns through sensitivity analyses and can be used for model calibration.

This paper presents a special use case in urban economics. If the first approach was based on citizens' behaviour related to some specific system; in this case, due to cultural aspects, the model will be based on industries' behaviour. The pilot city interested in this model, and participating in its development, is Yantai, China. The simulation model will be used to help a decision making process, in which, the industrial park of the city must be renovated in order to deal with the problem of high energy consumption together with the high generation of pollution.

Section 2 and 3 present the modeling approaches used during the model development: CPN and MAS. The case study is presented in Section 4; and the conclusions in Section 5.

2. COLOURED PETRI NETS

Coloured Petri Nets (CPN) is a simple yet powerful modelling formalism, which allows to properly modelling discrete-event dynamic systems that present a concurrent, asynchronous and parallel behaviour (Moore et al. 1996, Jensen 1997, Christensen et al. 2001). CPN can be graphically represented as a bipartite graph, which is composed of two types of nodes: the place nodes and the transition nodes. Place nodes are commonly used to model system resources or logic

conditions, and transition nodes are associated to activities of the real system. The entities that flow in the model are known as tokens and they have attributes known as colours. The use of colours allows modelling not only the dynamic behaviour of systems but also the information flow, which is a key attribute in decision making (Mujica and Piera 2011).

The formalism can be graphically represented by a bipartite graph where the place nodes are represented by circles and the transition nodes by rectangles or solid lines. Figure 2 illustrates a graphical representation of a CPN model.

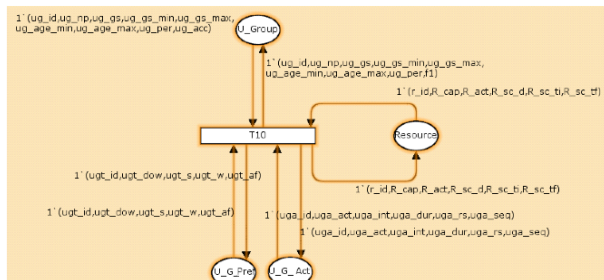

Figure 1: CPN Model Example

3. MULTI AGENT SYSTEMS

Multi-agent systems (MAS) have been applied in various fields related to Human Sciences, such as Political Sciences, Economics, and Social Sciences (Segal-Halevi (2012), Wilensky, 1999), in which an agent can be seen as an actor that has the power of “Agency”. The concept of agency is paramount since it extends beyond a single human being to organizations and social systems, where some have “agency” power with the ability to make decisions, while others do not have such power. These agents communicate, collaborate and negotiate among each other in order to meet their design objectives.

During the developing phase of MAS, it is necessary to simulate the system feasibility before the formal implementation. One way to achieve this objective is to develop a model to represent the behaviours of the MAS and then to simulate the model performance. In practice, a lot of time might be spent on modelling MAS behaviours while the resulting process models are typically still not compatible with the original system due to the lack of information about actual behaviours of the MAS. To avoid this difficulty, CPN models can be used to describe agents’ behaviour and predict the performance by means of state space analysis tools.

In FUPOL several MAS platforms has been analysed and, among them, Repast Symphony has been chosen as a simulation environment.

Repast Simphony is a widely used, free, and open source environment for agent-based modelling of complex adaptive system. The most recent version, 2.0, was released on March 5, 2012. Repast Simphony is a second-generation environment that builds upon the previous Repast 3 library (North et al. 2013).

Due to its flexibility it is suited to fully integrate the semantic rules present in CPN, and their implementation allow to govern the agents that interact within the environment in a more transparent way which is useful to understand the emergent dynamics caused by the agent interaction.

4. URBAN ECONOMICS - YANTAI

The municipality of Yantai needs to reduce the energy (electricity, gas, water, oil) consumption in the city and to reduce the generated pollution. There is a particular problem with the level of electricity consumption.

The initial idea was to start closing industries with high levels of electricity consumption year by year and let the establishment of other industries with reduced electricity consumption; however, there are other factors that they would like to consider. For that reason, the officers of Yantai municipality are planning to face the decision making process of closing industries, by considering several indicators and studying the effects of the decisions in some years time. This is the reason for the use of simulation to define the best conditions (indicators to consider) that will determine which industry must be closed.

The process can be seen as an industrial renovation process, in which, industries upgrade their infrastructure and/or organization in order to reduce consumptions and pollution emissions (to decrement the cost function value). Even they upgrade, companies with worse cost function value (higher cost function) will be closed every year.

4.1. Model Interpretation

As mentioned above, the model will be based on industries’ behavior. However, it is easy to understand that the behavior of an industry is determined by its personnel (director, president, etc.).

The model consists in a set of industries considered as candidates to be closed, and a set of industries’ profiles to be considered as potential established industries in Yantai. They are categorized by a set of attributes:

- Electricity Consumption
- Water Consumption
- Gas Consumption
- Oil Consumption
- Pollution generated
- Waste Indirect Jobs
- Direct jobs
- Exports Trade
- Imports Trade
- Revenue
- Local Government Taxes
- National Government Taxes
- Suppliers in the City
- Clients in the City
- GDP Closure Affectation

There is a cost function depending on these attributes, and the final user will be able to choose the attributes to consider in this cost function, and to assign a weight to each one depending on whether they should be more or less important. For example, it can be tested what would happen if it is taken into account only the consumption of gas, electricity and water, or if it is also taken into account direct jobs and taxes.

Depending on the ranking generated considering the cost function, the decision maker will decide which industries must be closed and which new profiles should be considered.

The simulation model lists the industries and the profiles in descendent order, from the one with more options to be closed, to the one in better conditions depending on the cost function. After one year, the city council will decide which industry must be closed. Therefore, the industries must react to try to modify the order of that list before the decision is taken.

An industry can decide whether to let time pass and see what happen, or to try to upgrade what is needed in order to change the order of the list, moving itself down. The economic capabilities of the industries will affect the possible improvements; moreover, according to which industry concerned and which sector, it will have more or less room for improvement depending on the used technology. Therefore, the final possible improvement will depend on two factors: Technical and Financial.

Considering that not always the expectations are satisfied, the model includes a random variable indicating the percentage of fulfillment for all the attributes involved in the cost function, because industries do not always accomplish with the 100% promised. The percentage of compliance heavily depends on the industry sector and culture. Initially, due to a lack of information about this parameter, percentages of compliance are randomly decided, and they are:

- More than 75% compliance in 35% of cases.
- More than 50% and less than 75% compliance in 25% of cases.
- Between 0% and 50% compliance in 25% of cases.
- And 0% of compliance in 15% of cases.

Final results will give an idea about a future picture of the industrial park in Yantai depending on the attributes used in the cost function.

4.2. Yantai CPN Model

The CPN model is used to analyze the behavior of the industries and the use of the cost function. It helps to determine how to model the behavior of the MAS model agents. The CPN model is not exactly replied in the MAS model due to after its analysis and presentation in Yantai, it was realized that some aspects must be changed, and there was no need to modify the CPN to be able to build the MAS model.

The CPN model has been developed using CPN Tools (<http://cpntools.org/>) and it is presented in the following subsections. However, due to the size of the model, it is not possible to include all the CPN in this paper. Therefore, the list of places types, the list of colors, and the list of transitions, together with one submodel of the CPN, are presented in the following subsections.

4.2.1. Places Types

The types of places are defined using the color assigned to them, and are the following:

- **Improvements:** It contains information regarding the industries upgrade. The first colour indicates the identifier of the industry, while the rest correspond to the percentage of improvement that applies to different indicators.
- **Fulfillment:** It indicates the percentage of satisfied upgrading.
- **Count, Actrans:** They are used as a controller to enable and disable transitions.
- **Or:** It is used to make comparisons.
- **LL:** It indicates the cost of each industry.
- **Result:** It indicates information about the results: industries position in the list and associated cost.
- **Emp:** List of industries to consider.
- **Weight:** It determines the importance of the attributes in the cost function. One value for each industry attribute.
- **FinalImp:** Place with the improvements to be applied.

The places are named N_{xx} , where xx is a number and they are of one of the types described above. Table 1 includes the places for each place type. Notice that there are 57 places; however, due to the CPN software, which do not allow to duplicate places, some of the places are between parenthesis, indicating they represent the same as the place in front.

Table 1: Places by type (depending on the color)

Place Type	Places with that color
Improvements	N39, N42 (N56)
Fulfilment	N40
Count	N12 (N15), N19 (N23, N26), N33 (N57)
Actrans	N2, N10 (N58), N16 (N20), N18, N27 (N48, N51), N32 (N52)
Or	N13, N24 (N47)
LL	N8 (N9, N22), N11, N14, N17, N25 (N49), N28 (N29), N34 (N38), N36 (N43, N50), N41 (N55)
Result	N21 (N54), N53
Emp	N4, N5, N6 (N31), N7 (N30), N35 (N37), N45
Weight	N1, N3 (N46)
FinalImp	N44

4.2.2. Colors

There is a color for each place type. Table 2 to Table 11 present the set of colors for each place type color. Left

column is the type of variable and right column, the meaning of the color.

Table 2: Colors at Improvements place color

INT	ID of the company
REAL	Percentage of improvement in electricity consumption
REAL	Percentage improvement in gas consumption
REAL	Percentage improvement in CO2 emissions
REAL	Percentage of improvement in water consumption

Table 3: Colors at Fulfillment place color

REAL	Possible satisfaction of the proposed upgrade
------	---

Table 4: Colors at Count place color

INT	Control variable to enable or disable transitions
INT	Control variable to enable or disable transitions

Table 5: Colors at Actrans place color

INT	Control variable to enable or disable transitions
-----	---

Table 6: Colors at Or place color

INT	ID of the industry
REAL	Weight associated with the industry
INT	Control variable to enable or disable transitions

Table 7: Colors at LL place color

INT	ID of the industry
REAL	Weight associated with the industry

Table 8: Colors at Results place color

INT	Position in the list
INT	ID of the industry
REAL	Weight associated with the industry

Table 9: Colors at Emp place color

INT	Company ID
REAL	Electricity consumption.
REAL	Gas consumption.
REAL	CO2 emissions.
REAL	Water consumption.
REAL	Number of jobs.
REAL	Number of suppliers in the area.
REAL	Number of customers in the area.
REAL	Local government taxes.
REAL	Surface used.
REAL	Transportation (private).
REAL	Fleet company.

Table 10: Colors at Weight place color

INT	Weight associated with the consumption of electricity
REAL	Weight associated with the consumption of gas
REAL	Weight associated CO2 emissions
REAL	Weight associated with the consumption of water
REAL	Weight associated with the number of jobs
REAL	Weight associated with the number of suppliers in the city
REAL	Weight associated with the number of clients in the city
REAL	Weight associated with local government taxes
REAL	Weight associated with the surface used
REAL	Weight associated with transport (private)
REAL	Weight associated with the company's fleet

REAL	Weight associated with the consumption of electricity
------	---

Table 11: Colors at FinalImp place color

INT	Percentage applied to improve power consumption.
REAL	Percentage applied to improve gas consumption.
REAL	Percentage applied to improve CO2 emissions.
REAL	Percentage applied to improve water consumption.

4.2.3. Transitions

Table 12 presents the list of transitions: Id, input places, output places and description.

Table 12: List of Transitions

ID	Input	Output	Description
T1	N1, N2	N3	Choosing what will be chosen to perform the simulation heuristic.
T2	N3, N4	N7, N8, N57, N58	Calculating the weight associated with each industry already established.
T3	N3, N5	N6, N8	Calculating the weight associated with each industry to be established.
T4	N9, N10	N9, N11	Selection of industries already established in the whole business.
T5	N11, N12, N13	N12, N13, N14	Comparison of the weights associated to find the smallest.
T6	N13, N14, N15, N16	N13, N15, N16, N17	Selection of the industry associated with the lowest weight.
T7	N17, N18, N19, N20	N18, N19, N20, N21	Formation of a list of established industries ordered more associated with less weight.
T8	N12, N14, N16	N11, N12, N16	Return the set of tokens industries are being sorted.
T9	N22, N23, N24	N23, N24, N25	Comparison of the weights associated to find the smallest.
T10	N24, N25, N26, N27	N24, N26, N27, N28	Selection of the industry associated with the lowest weight.
T11	N23, N25, N27	N22, N23, N27	Return the set of tokens industries are being sorted.
T12	N29, N30, N32, N33	N30, N32, N33, N34, N35, N36	Select established industries and decide if they have to raise their consumption or not.
T13	N29, N31	N31, N36	Select industries that want to send them down to the final result.
T14	N37, N38, N39, N40	N40, N41, N42, N43, N44, N45	Select the percentage improvements and compliance with these associated industries. Calculate improve overall application.
T15	N44, N45, N46, N47, N48	N46, N47, N48, N49.	Calculating the weight associated with the new industry with the improvements implemented.
T16	N50, N51, N52	N51, N52, N53	Make a list of the final result.

4.2.4. Submodel

Figure 2 presents part of the CPN model, which is used to determine the order of the industries depending on the cost function.

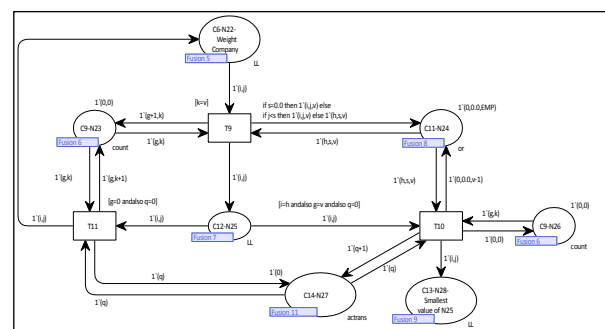

Figure 2: Part of the developed CPN model

4.3. Yantai MAS Model

The introductory part of this Section 4 and Section 4.1 already introduced how the MAS model works. The CPN model is the base of the MAS model; however, in that case, there are some modifications due to the results of the simulation of the CPN and the feedback obtained from the responsables of Yantai Municipality.

The main difference between both models is that in the CPN model, the decisions to make at the end of the year were two:

1. Which industry or industries must be closed
2. Which industry or industries must be forced to upgrade

However, in the final MAS model, industries decide if they upgrade by themselves depending on their possibilities, their situation in the list, and considering if the industries of the same sector are upgrading or not.

The cost function includes some of the indicators presented in Section 4.1 multiplied by a weight that can be set to 0. The considered indicators with their sign in the cost function are:

- Electricity Consumption (+)
- Water Consumption (+)
- Gas Consumption (+)
- Oil Consumption (+)
- Pollution generated (+)
- Direct jobs (-)
- Local Government Taxes (-)
- National Government Taxes (-)
- Suppliers in the City (-)
- Clients in the City (-)

4.4. Test Results

Due to the partial lack of data, tests have been performed using real data (not complete) and randomly generated data. There is data from 8 real industries containing electricity, water and gas consumption, direct jobs, local taxes (partially), and suppliers in the city. It is considered that 2 industries are upgrading from the beginning (I1 and I2). Four new industry profiles are randomly generated (I9, I10, I11, I12), the simulation time is 5 years with periods of 1 year in which one industry is closed and a new one is established in the city. Table 13 presents the industries' data. If the value is N/A, it is considered as 0.

Table 13: Industries Input Data

Id	Electricity (kw)	Water (tons)	Gas (tons)	Direct Jobs	Loc Tax (bilions)	Suppliers in city	Upgrading
I1	866325	10220000	1800	700	90	2	1
I2	970132	13212000	2100	650	2.1	3	1
I3	755327	9800000	20	150	N/A	5	0
I4	1200	3000	0	12	N/A	0	0
I5	1500	2100	0	15	N/A	0	0
I6	872121	120000	0	100	N/A	6	0
I7	1013222	17000000	2300	200	70	8	0
I8	731121	2100000	0	120	3.95	55	0
I9	20000	10000	0	20	0.5	4	0
I10	10000	8000	1500	15	0.5	6	0
I11	15000	20000	500	10	0.5	5	0
I12	5000	7000	100	25	0.5	10	0

Three different tests have been performed, depending on the cost function weights:

- Test 1: Just the weight for electricity consumption is set to 1; all the others to 0.
- Test 2: Weights for electricity, water and gas consumption set to 1; all the others to 0.
- Test 3: All weights set to 1.
- Test 4: Weights for direct jobs, local taxes and number of suppliers set to 1; all the others to 0.

The initial list of ordered industries (first row) and ordered industry profiles (second row) depending on the cost function, for each test, are:

- Test 1: I7, I2, I6, I1, I3, I8, I5, I4; I12, I10, I11, I9
- Test 2: I7, I2, I1, I3, I8, I6, I4, I5; I12, I10, I9, I11
- Test 3: I7, I2, I1, I3, I8, I6, I4, I5; I12, I10, I9, I11
- Test 4: I4, I5, I6, I3, I8, I7, I2, I1; I12, I9, I10, I11

And the final lists of ordered industries (first row) and the list of closed industries (second row), by order, are:

- Test 1: I1, I8, I9, I11, I10, I12, I4, I5; I7, I2, I6, I3
- Test 2: I8, I6, I11, I9, I10, I12, I5, I4; I7, I2, I3, I1
- Test 3: I8, I6, I11, I9, I10, I12, I5, I4; I7, I2, I3, I1
- Test 4: I11, I10, I9, I12, I8, I7, I2, I1; I4, I5, I6, I3

The total of the indicators considering all the industries are usually reduced irregularly depending on the indicators' weights.

Table 14: Total indicators' values

Test	Electricity (kw)	Water (tons)	Gas (tons)	Direct Jobs	Loc Tax (bilions)	Suppliers in city
0	5210948	52457100	6220	1947	166.05	79
1	1259338	9135528	3397	952	95.95	82
2	1353646	1807049	2100	363	5.95	86
3	1353646	1807049	2100	363	5.95	86
4	3545791	41150998	8090	1786	595.06	93

Table 14 shows the difference between the performed tests. When giving importance just to electricity (Test 1), its consumption decrease a lot after 5 years; however, the number of direct jobs decrease too much. When giving importance to all the energy consumptions (Test 2 and 3), the consumptions decrease together with the direct jobs, which are dramatically reduced to around 20% of the initial number of direct jobs. Notice that the negative indicators do not affect the results when the consumptions are also considered. This is due to the units used and the weights. It will be necessary to perform a high number of tests in order to determine which kind of units to use or which proportions for the weights.

Test 4 gives importance to the negative indicators (direct jobs, local taxes and suppliers) and the results confirm that these indicators are more or less kept or increased; however, the consumptions are not reduced as they are when considering them in the cost function.

5. CONCLUSIONS

Under the framework of the FUPOL project one challenging task is the policy modelling and analysis. The proposed model allow the study and analysis of a urban economic model using MAS modelling and simulation, in which, the agents represent industries instead of persons, as made in the rest of the simulation models developed for the FUPOL project.

Results show how the model can be run using different cost functions, which will allow the analysis of a large number of alternatives. The Yantal City Council has no idea about which indicators are the best ones in order to make the correct decisions. Using this model they will be able to test what would happen depending on which indicators and weights they select for the cost function.

ACKNOWLEDGMENTS

This work is funded by Future Policy Modelling Project (FUPOL), FP7-ICT-2011-7, ref. 287119 (www.fupol.eu).

REFERENCES

- Buil, R. and Piera, M.A. (2013). A MAS Approach Based on Coloured Petri Net Formalism for Urban Policy Design, *25th European Modeling and Simulation Symposium, EMSS 2013*, pp. 510.
- Christensen, S., Jensen, K., Mailund, T., Kristensen, L.M., 2001. State Space Methods for Timed Coloured Petri Nets. Proc. of 2nd International Colloquium on Petri Net Technologies for Modelling Communication Based Systems, 33-42, Berlin.
- Islam M. S., 2008, Towards a sustainable e-Participation implementation model, *European Journal of ePractice*, www.epracticejournal.eu 1 N° 5, October 2008, ISSN: 1988-625X
- Jensen, K., 1997. Coloured Petri Nets: Basic Concepts, Analysis Methods and Practical Use. 1 Springer-Verlag, Berlin.
- Moore, K.E., Gupta, S.M., 1996. Petri Net Models of Flexible and Automated Manufacturing Systems: A Survey. *International Journal of Production Research*, 34(11), 3001-3035.
- Mujica, M.A., Piera, M.A., 2011. A Compact Timed State Approach for the Analysis of Manufacturing Systems: Key Algorithmic Improvements, *International Journal of Computer Integrated Manufacturing, Vol.24 (2)*, February 2011.
- North, M.J., N.T. Collier, J. Ozik, E. Tataru, M. Altaweel, C.M. Macal, M. Bragen, and P. Sydelko, 2013. Complex Adaptive Systems Modeling with Repast Symphony, *Complex Adaptive Systems Modeling, Springer, Heidelberg, FRG (2013)*.
- Piera, M.A., Buil, R. and Ginters, E. (2013). "Validation of Agent-Based Urban Policy Models by means of State Space Analysis", 8th EUROSIM Congress on Modelling and Simulation, pp. 403-408.
- Piera, M.A., Buil, R. and Mújica, M. (2014). "Specification Of CPN Models Into MAS Platform For The Modelling Of Social Policy Issues: FUPOL Project", Accepted for International Journal of Simulation and Process Modelling (IJSPM).
- Segal-Halevi, Erel, 2012, NetLogo Land-Random model.
- Wilensky, U., 1999, NetLogo, <http://ccl.northwestern.edu/netlogo/>, Center for Connected Learning and Computer-Based Modeling, Northwestern University, Evanston, IL

AUTHORS BIOGRAPHY

Roman Buil received the B.S. degree in Mathematics from Universitat Autònoma de Barcelona, Barcelona, Spain, in 2002, the M.S. degree in industrial engineering - advanced production techniques from Universitat Autònoma de Barcelona, in 2004. He is currently working towards the Ph.D. degree in industrial engineering - advanced production techniques at the same University. He is research scientist, assistant teacher and project manager at the Logistics and Aeronautical Unit of the Telecommunications and Systems Engineering Department of Universitat Autònoma de Barcelona. His research interests include modelling and simulation methodologies, optimization techniques, policy modelling, production planning and decision making for production planning and logistics. He is member of LogiSim, a recognized research group on Modelling and Simulation of Complex Systems and he has been involved in industrial projects working as consultant of different companies. He participates in FP7 FUPOL Project No.287119.

Miquel Angel Piera Eroles is the delegate for Technical Innovation Cluster, and director of LogiSim, a recognized research group on Modeling and Simulation of Complex Systems. He is Full time Professor in the System Engineering Department at Universitat Autònoma de Barcelona (UAB). Graduated with excellence from UAB in Computer Engineering (1988), Msc from University of Manchester Institute of Science and Technology in Control Engineering (1991), and he got his Phd in 1993. He is member of the Editorial board of 3 international journals and Editor in Chief of IJBRM. Dr Piera has been general chair and invited speaker of many International conferences. He has been nominated as Deputy Director of the UAB Engineering School and Coordinator of the Spanish CEA-IFAC research team on Modeling and Simulation. He has coordinated many research and industrial projects, he has also participated in some EC funded research and academic projects, such as: LOGIS

MOBILE LV/B/F/PP-172.001 (2004-2006), Curriculum Development on Logistics and Supply Chain Management. 134522-LLP-1-2007-1-ESERASMUS-ECDSP and FP7 FUPOL No.287119.

Egils Ginters is director of Socio-technical Systems Engineering Institute. He is full time Professor of Information Technologies in the Systems Modelling Department at the Vidzeme University of Applied Sciences. He is a Senior member of the Institute of Electrical and Electronics Engineers (IEEE), member of European Social Simulation Association (ESSA) and Latvian Simulation Society. He participated and/or coordinated some of EC funded research and academic projects: FP7 FUPOL project No. 287119 (2011-2014), FP7-ICT-2009-5 CHOREOS project No. 257178 (2010-2013), e-LOGMAR-M No.511285 (2004-2006), SocSimNet LV/B/F/PP-172.000 (2004-2006), LOGIS MOBILE LV/B/F/PP-172.001 (2004-2006), IST BALTPORTS-IT (2000-2003), LOGIS LV-PP-138.003 (2000-2002), European INCO Copernicus DAMAC-HP PL976012 (1998-2000), INCO Copernicus Project AMCAI 0312 (1994-1997). His main field of interests involves: systems simulation technologies, logistics information systems, and technology acceptance and sustainability assessment. He has more than 140 scientific articles related with the research fields.

Artis Aizstrauts is researcher at Socio-technical Systems Engineering Institute and lecturer in the faculty of Engineering of the Vidzeme University of Applied Sciences. His research interests are software designing and distributed simulation communication environments. He has more than 15 scientific articles related with the research fields.